

CONTENTS

1. General safety precautions.....	3
2. Packaging.....	3
2.1. Dimensions and contents.....	3
2.2. Handling and storage.....	3
3. Before installation.....	4
3.1. Mechanical specifications required.....	4
3.2. Central control unit power supply.....	4
3.3. Wiring connection between central control unit and generator light.....	4
4. Installation.....	5
4.1. Positioning the x-ray unit's structure.....	5
4.2. Wall-mounted plate for supporting the x-ray unit.....	5
4.2.1. Vertical SINGLE STUD installation with wooden post.....	6
4.2.2. Horizontal SINGLE STUD installation with wooden post.....	6
4.2.3. Vertical SINGLE STUD installation with iron post.....	6
4.3. Extension arm.....	7
4.3.1. PASS THROUGH installation extension arm.....	8
4.4. Installing the double pantograph arm.....	9
4.5. Installing the RX DC Plus generator.....	11
4.6. Installing the RX DC eXTend generator.....	11
4.7. Balancing the double pantograph arm.....	14
4.8. Adjusting the double pantograph arm end-stops.....	15
4.9. Wall-mounted plate wiring connections.....	15
4.10. Wall-mounted plate wiring connections.....	16
4.11. Completion of wall-mounting plate and holder for hand-held.....	17
5. Factory settings.....	18
6. Turning on.....	18
6.1. Turning The X-ray equipment on and off.....	18
6.1.1. Turning on the basic X-ray unit.....	18
6.1.2. Turning on the handheld.....	19
6.1.3. Control panel.....	19
6.1.4. Automatic handheld shut off.....	20
6.1.5. Hand-held stand-by time.....	20
6.1.6. Checking the set parameters.....	21
6.1.7. Factory settings.....	22
7. Batteries and charge level indication.....	22
8. X-ray generator indicator light.....	22
9. Position of the patient.....	23
10. Putting the x-ray unit cone into the required position.....	23
11. Position of the X-ray plate or sensor.....	24
12. Checking the exposure time on the display.....	25
12.1. Setting the exposure mode and time.....	25
12.2. Setting the mode and exposure time in USER mode.....	26
13. Procedure to be followed when taking the x-ray.....	27
14. Technician and user setup menu.....	28
14.1. Setting the safety unlock mode.....	29
14.2. Setting the operating mode.....	29
14.3. Setting the type of movable collimator.....	29
14.4. Restoring factory settings.....	29
14.5. Calibrating the X-ray head.....	30
15. Actuator unit.....	31

16. Control unit card Code 97660515.....32
17. Basic head control card Code 97660514 33
18. Actuator control card Code 9766059136
19. X-ray head.....37
19.1. Replacing the slip ring assembly39
19.2. Check occupation of radiofrequencies for RXDC MyRay PDA.....41

1. General safety precautions

Cefla Sc - Cefla Dental Group guarantees the safety, reliability and performance of the equipment under the following conditions:

- Installation and technical service is performed by authorized technicians using Cefla Sc - Cefla Dental Group original spare parts.
- The electrical system in the dental surgery corresponds to standards I.E.C. 60364-7-710;V2 (Standards regarding electrical systems in a medical environment) or equivalent standards currently in force in the country where the equipment is installed.
- The place where the x-ray unit is installed must comply with official directives regulating radiation in the country where the equipment is used.
- The equipment is operated as directed in the instructions manual..

This device complies with part 15 of the FCC Rules. Operation is subject to the following two conditions: (1) This device may not cause harmful interference, and (2) this device must accept any interference received, including interference that may cause undesired operation.

This equipment has been tested and found to comply with the limits for a Class B digital device, pursuant to part 15 of the FCC rules. These limits are designed to provide reasonable protection against harmful interference in a residential installation. This equipment generates, uses and can radiate radio frequency energy and, if not installed and used in accordance with the instructions, may cause harmful interference to radio communications

Changes or modifications not expressly approved by the party responsible for compliance could void the user's authority to operate the equipment.

2. Packaging

2.1. Dimensions and contents

• **DIMENSIONS: 103X53X35 CM**

• **WEIGHT: 35 KG**

• **CONTENTS:**

- Documentation and guarantee
- Disposable jig for installation
- Kit
- Wall back-plate (if requested)
- Wall-mounted plate
- Generator
- Tube
- Extension
- Collimator
- Double pantograph arm

2.2. Handling and storage

Indications regarding storage, handling and unpacking are given on the outside of the cardboard packaging.

These indications must be strictly observed.

- 1) The package must be kept upright in the direction indicated by the arrows at all times during handling and storage.
- 2) Avoid banging the package.
- 3) Keep the package free from damp.
- 4) Do not use hooks to handle the package.
- 5) A nameplate indicates the required ambient conditions for storage.
 - a) temperature from -15° to 50° C.
 - b) relative humidity from 10 to 90%
 - c) atmospheric pressure from 500 to 1060 hPa.



1



2



3



4

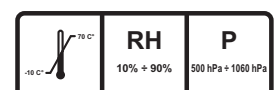

5

3. Before installation

3.1. Mechanical specifications required

If the wall is thin (hollow bricks or similar), use the backplate (part no. 9660048) to be mounted on the wall or placed on the side of the wall opposite the wall where the unit is to be installed.

Decide on a suitable system for fixing the plate according to the characteristics of the wall and its ability to resist a pull force of 220 Kg applied at each anchorage point.

If the wall is made of cement or solid bricks, use the wall plugs supplied.

Alternatively we recommend using the “FISHER” chemical wall plugs which include:

- **Braid type injection insert (item FIP 16X85).**
- **Threaded bar with bar and washer (item FIP 16M, 8X110).**
- **Chemical fixer (item FIP C 150).**

3.2. Central control unit power supply

The supply line running to the central control unit must be 3x2.5 mm and protected by a bipolar circuit breaker which conforms to the relevant electrical codes (10 A, 250 V, breaking power at least 6000 A, distance between contacts at least 3 mm).

The colour of the three conductors (LINE, NEUTRAL and GROUND) must correspond to that established by regulations.

3.3. Wiring connection between central control unit and generator light

This connection enables the generator light (optional) located outside the surgery to be turned on.

To connect the LP generator light to the central control unit, use 2 conductors having a cross-section of 0.5 mm (see paragraph 4.8.).

LP light supply: 230V - 3x2.5 mm line.

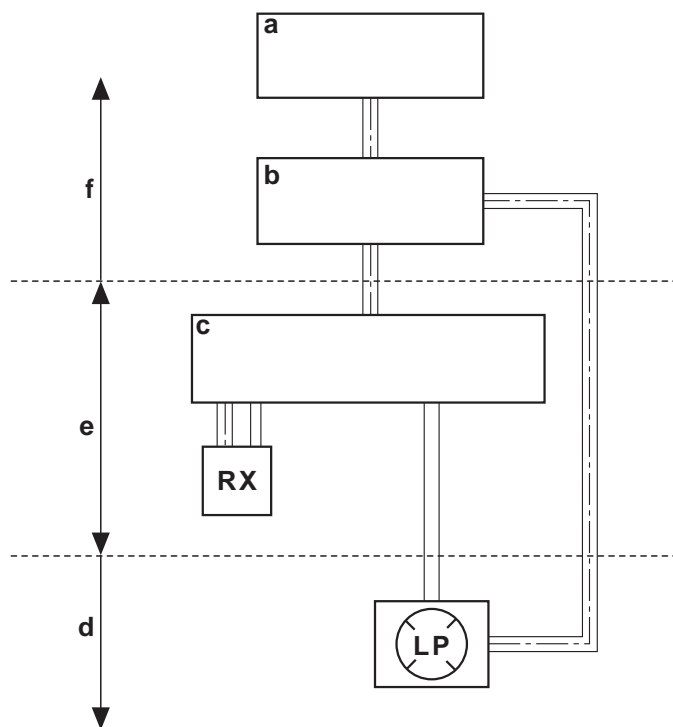

Legenda:

- a) SUPPLY LINE
- b) CIRCUIT BREAKER 10 A
- c) CENTRAL CONTROL UNIT
- d) OPTIONAL
- e) SUPPLIED
- f) NOT SUPPLIED

4.2.1. Vertical SINGLE STUD installation with wooden post

- Insert the 4 TPSEI M8x35 screws with heads that allow them to be driven with a screw driver provided in the interface plate
- Run the power cord through one of the holes in the interface plate
- Attach the interface plate to the wooden post with no. 3 dia. 3/8" x L 3" wood screws (not supplied)
- Attach the x-ray unit's wall-mounting plate to the interface plate by tightening the washers and nuts provided on the TPSEI M8x35 screws with heads that allow them to be driven with a screw driver

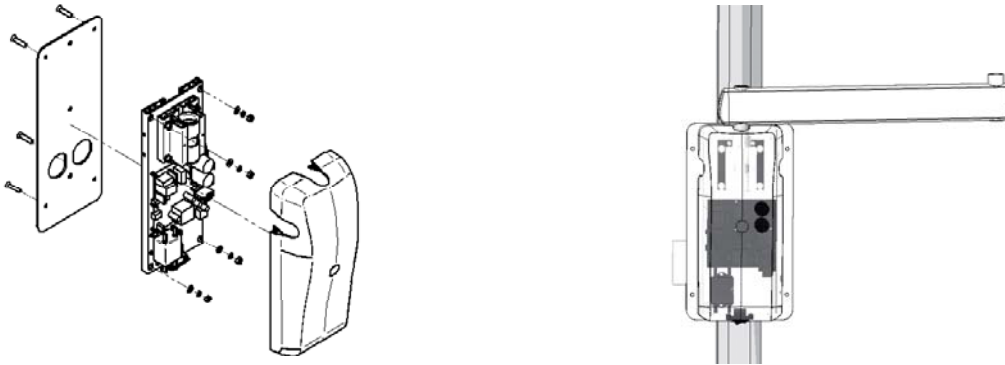

4.2.2. Horizontal SINGLE STUD installation with wooden post

The interface plate is not needed for 1.5" wooden posts with 16" spacing. Simply attach the RX-DC plate with no. 4 dia. 3/8" x L 3" wood screws (not supplied)

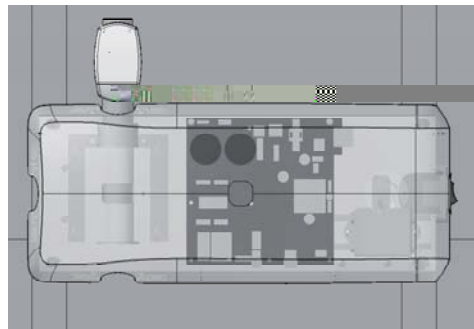

4.2.3. Vertical SINGLE STUD installation with iron post

- Attach the wall-mount counter-plate to the iron posts (not completely seen) with the threaded bars and screws provided
- Attach the interface plate to the counter-plate. Secure the x-ray unit's wall-mounting plate to the latter

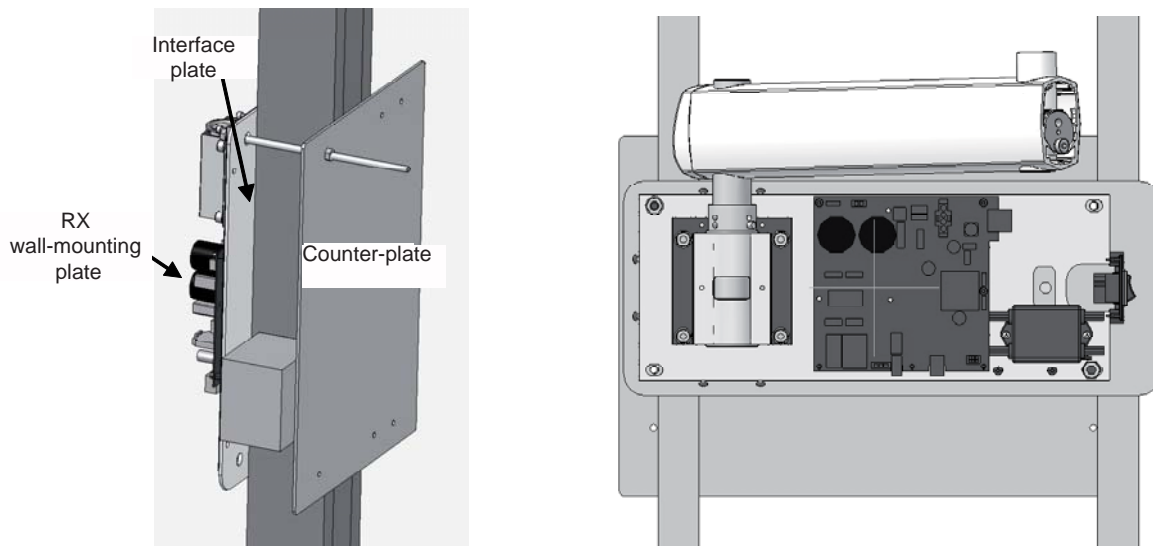

4.3. Extension arm



WARNING!

Do not lubricate the pin of the extension arm: the wall-mounted plate is provided with self-lubricating bushings.

Figure B

- Insert the pin (b) of the extension arm (c) in the hole provided in the wall-mounted plate.
- Take the clutch (a) from the kit, install it on the plate using the corresponding screws and adjust the arm (c) as required.

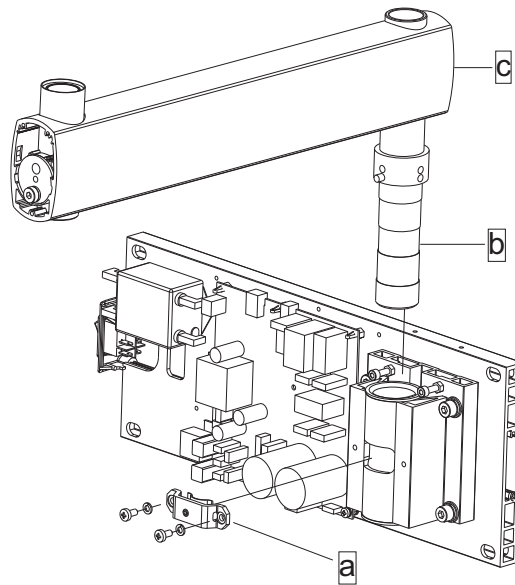

Figure C

- Use a spirit level to check that the arm (c) is slightly tilted upwards (approx. 1°). If necessary add a shim to the plate near the bottom wall plugs (d).
- Fully secure the plate.

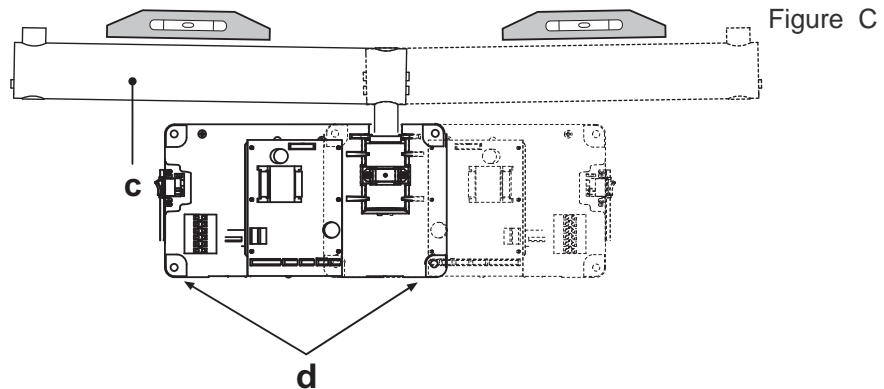
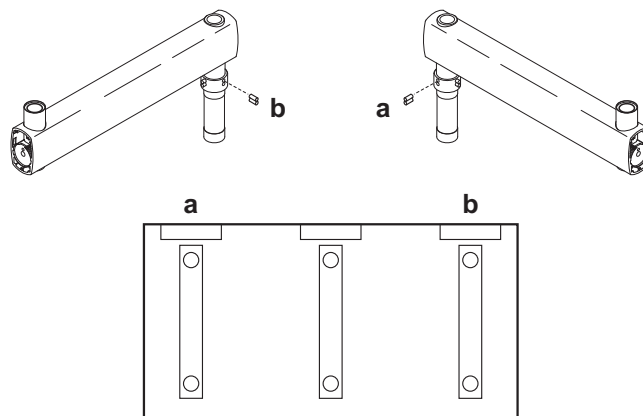

Figure D

- If the x-ray unit is installed in one of the corners of the dental surgery, make sure the extension arm cannot rotate too far (90°) by installing the two end-stop pins (included in the kit) on the x-ray unit itself.
- Find the right position for installing the pair of pins (a, b) and insert them in the holes provided using a hammer.



4.3.1. PASS THROUGH installation extension arm

Install inside cabinet model PXTG92 42.5" x 49"

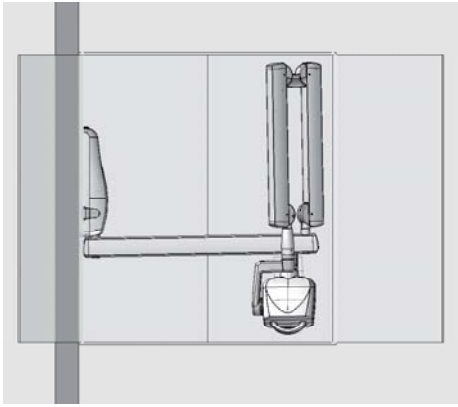

Switch at top h=191cm

Check the direction of the pin support: it should be set as shown in figure (A) for this type of installation.

Insert the extension arm pin in the hole in the wall-mounting plate from below. Place the washer supplied on top of the pin and forcefully tighten the ring nut with the pin spanner provided, as shown in the figure (B).

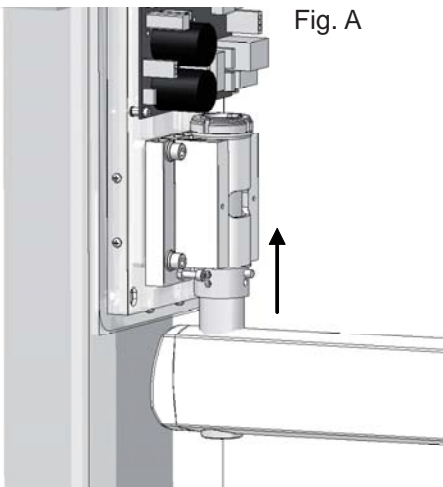

Fig. A

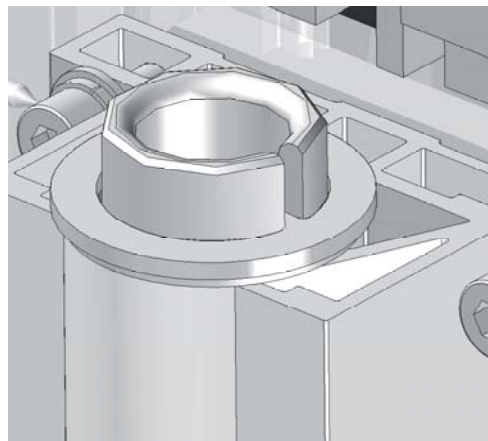

Fig. B

Install the clutch (a) as directed in paragraph 4.3 figure (B) .

4.4. Installing the double pantograph arm



WARNING!

The arms are supplied secured together by a belt.

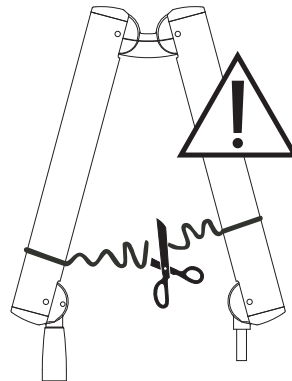

This belt **should not be removed** until the two free ends of the arms have been connected to their corresponding attachments: the extension arm (already secured to the wall) and x-ray head. If the belt is loosened before fixing the arms in place, releasing them abruptly could damage them and the operator risks being injured.

Figure E

- Take the washer (f) from the kit and position it at point (i) corresponding to the extension arm (c).
- Pass the cable (m) of the pantograph arm (e) through the extension arm (c) so that it comes out of the hole below.
- Install the pantograph arm (e) on the extension arm (c)

NOTE:

The extension arm's bushing is self-lubricating.

Do not lubricate the pin of the double-pantograph arm.

- Pass the cable (m) through the inside of the extension arm (c) so that it comes out of the wall-mounted plate.
- Install the plugs (g) in the corresponding holes in the extension arm (c).

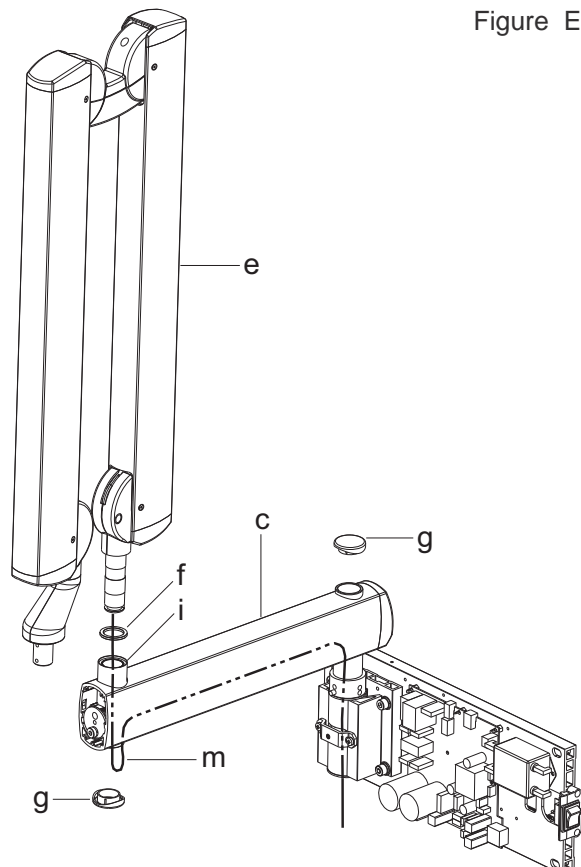

Figure E

Figure F

- Take the grub screw used to stop rotation (o) from the x-ray unit kit and tighten it at point H (tighten it fully and then loosen by ½ turn).

 **NOTE: Turn the pantograph arm to check that the adjustment has been made properly.**

- Take the clutch assembly (friction element, screw and 4 curved washers) from the x-ray unit kit and install it at point

 **NOTE: Insert the curved washers (j) and the friction element (k) as indicated in figure F.**

 **NOTE: The friction element (k) can be placed in the correct position (vertical cut) by inserting a screwdriver in the hole provided for the screw (n).**

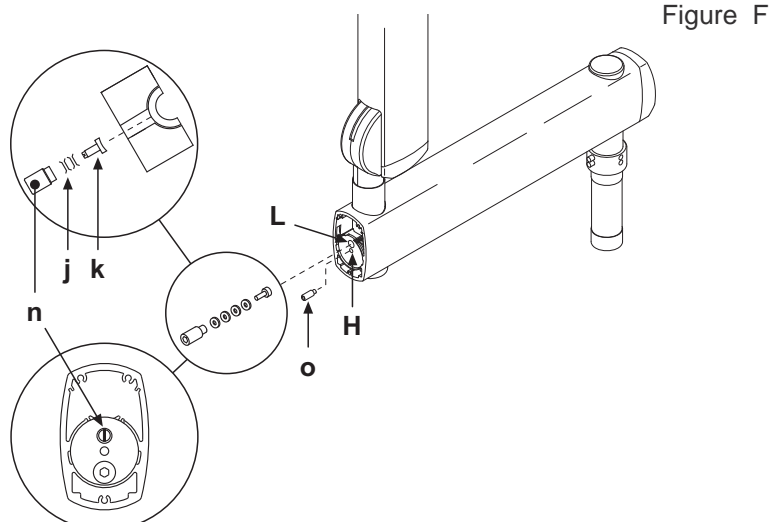

Figure F

Figure G

- Adjust the clutch which has just been installed.

 **NOTE: Turn the pantograph arm during the adjustment to check that the clutch is providing the correct amount of friction.**

- Install the plugs (p) on the extension arm (c).

- Attach the adhesive bumper (q) (supplied in the kit) in the centre of the plug at the point indicated in the diagram.

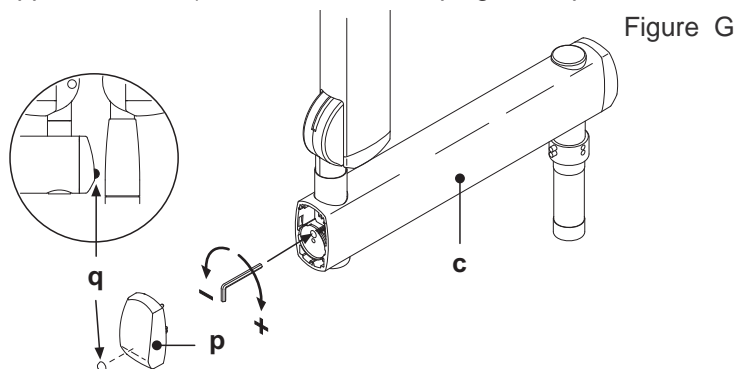

Figure G

Figure H

- There are 2 end-stop screws in the wall-mounted plate to which Loctite has been applied to provide friction. These have been adjusted according to the length of the extension arm supplied.

 **NOTE: Work on the screw itself (a) in order to make the extension arm stop before or after.**

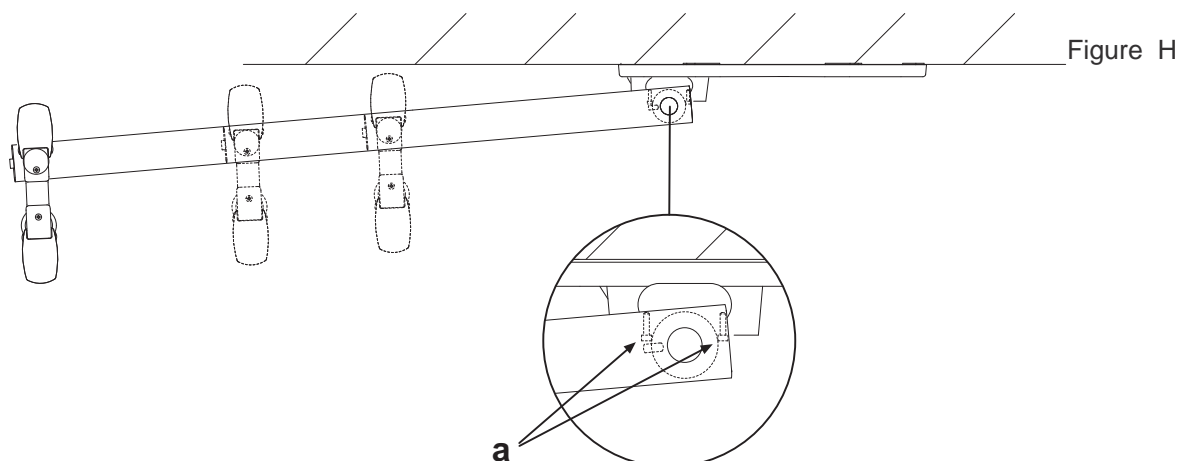

Figure H

4.5. Installing the RX DC Plus generator

Figure I

- Take the generator out of the packaging.
- Insert the pin (a) in the sleeve making sure the respective openings match and secure with the screws (b) provided.
- Insert the power cable in the generator's pin and run it out of the opening (c) provided.
- Lastly, put on the two side covers montare (d).

Figure I

4.6. Installing the RX DC eXTend generator

- Take the generator out of its packaging.
- Lubricate the bush of the pantograph arm and the generator pivot point with grease designed for bearings. (FIAT MR3).

Figure J

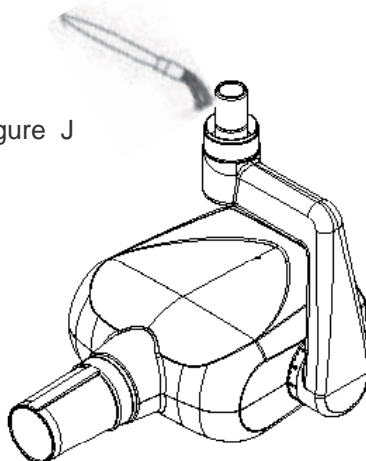

- Take the washer (a) from the kit supplied and fit it in the pin (b) with the protruding tooth (c) pointed towards the right-hand head. (see fig.K)

Figure K

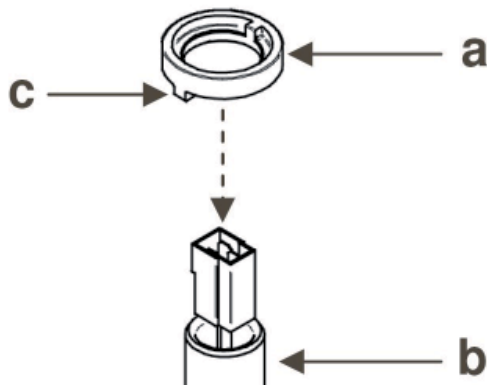

Position the protruding tooth (c) of the washer (a) in zone 1 of the pin (b). (see fig. L)

⚠ WARNING! DO NOT position the protruding tooth (c) of the washer (a) in zone 2 of the pin (b).

Figure L

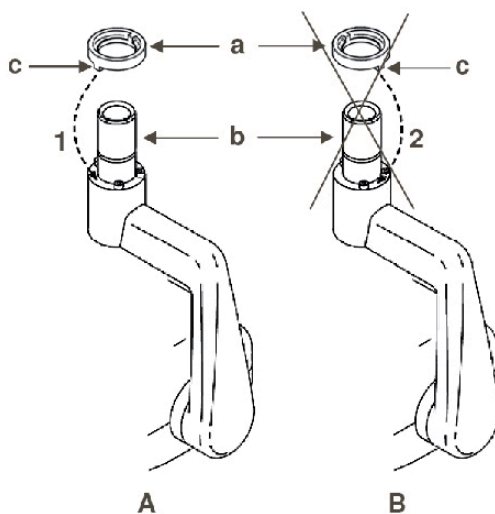

- Insert the power supply cable of the pantograph arm in the generator pin until it comes out of the hole below (see point c – fig. M).
- Raise the cover (a).
- Insert the pin in the sleeve so that it corresponds to the openings provided and then Fit the mounting yoke (d) supplied.
- Lower the cover (a) so that the hole (f) in the cover (a) is aligned with the hole in the internal washer (e).
- Fit the M4x6 self-locking grub screw (g) into the hole (f) and tighten it to 1 mm below the outer surface of the cover (a).

Figure M

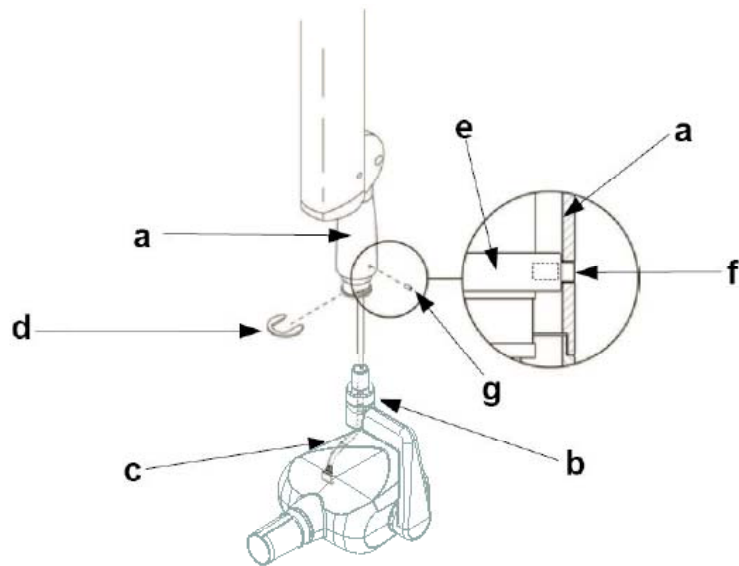

- Fit the connector of the pantograph arm cable to that of the generator cable.
- Place them inside the hole provided (c).
- Fit the plug (e) supplied into the hole then tighten the screw that is already in place. (see fig. N)

Figure N

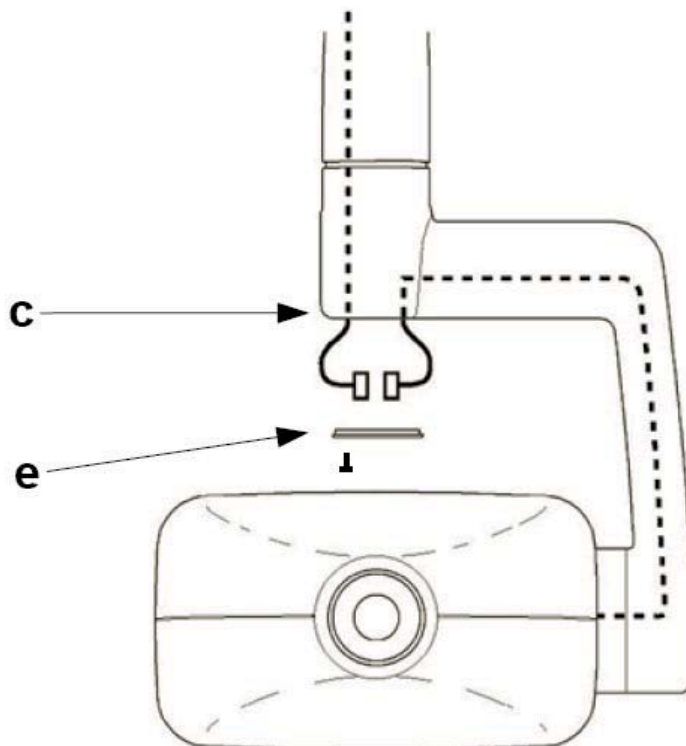

4.7. Installing the collimator

- Take the collimator out of the packaging:
round in case of RX DC extend

Figure O

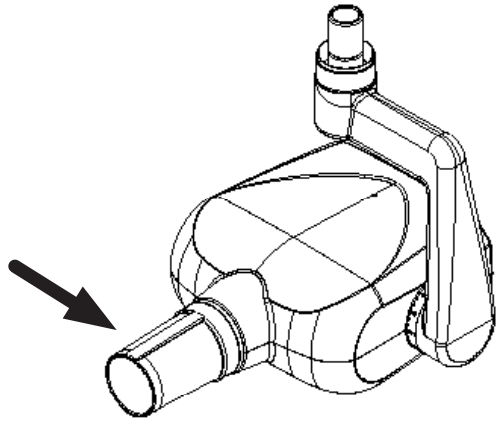

round or rectangular in the case of RX DC HyperSphere Plus

Figure P

- Insert it in the generator and block it in place by turning clockwise.

4.8. Balancing the double pantograph arm

Figure Q

If the double pantograph arm does not stay in a stable position, adjust the spring tension by using an 8mm Allen wrench about 20cm long.

- To adjust the arm (a) connected to the extension: position it as shown in the figure and place the wrench at point A.

NOTE:

TIGHTEN (clockwise) if the arm tends to move down.

LOOSEN (anti-clockwise) if the arm tends to move up.

- To adjust the arm (b) connected to the generator: put the 2 covers (c) and (d) on the front pivot point, move the arm (b) into a horizontal position and insert the key in point B.

NOTE:

TIGHTEN (clockwise) if the arm tends to move down.

LOOSEN (anti-clockwise) if the arm tends to move up.

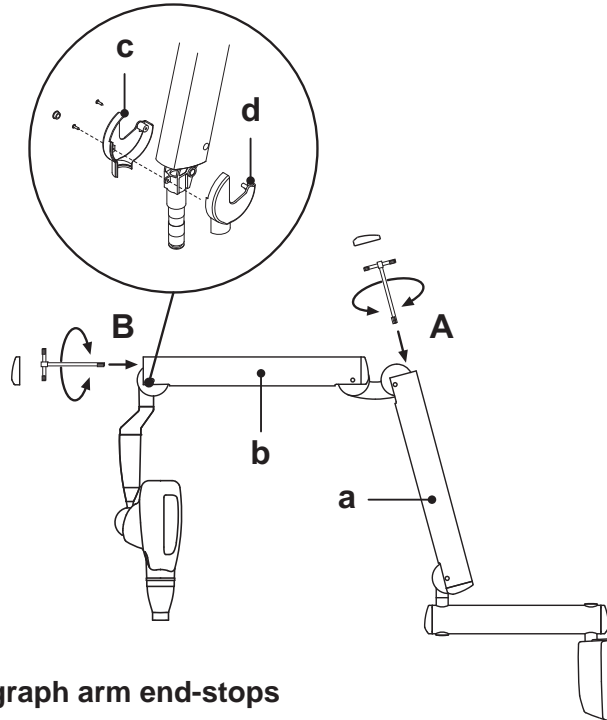

Figure Q

4.9. Adjusting the double pantograph arm end-stops

Figure R

If the end-stops of the double pantograph arm need to be adjusted, work on the screws (i - l - m - n) shown in the diagram.

NOTE:

- To adjust the screw (n) on the articulated joint of the extension side place the relevant arm (a) in a horizontal position.

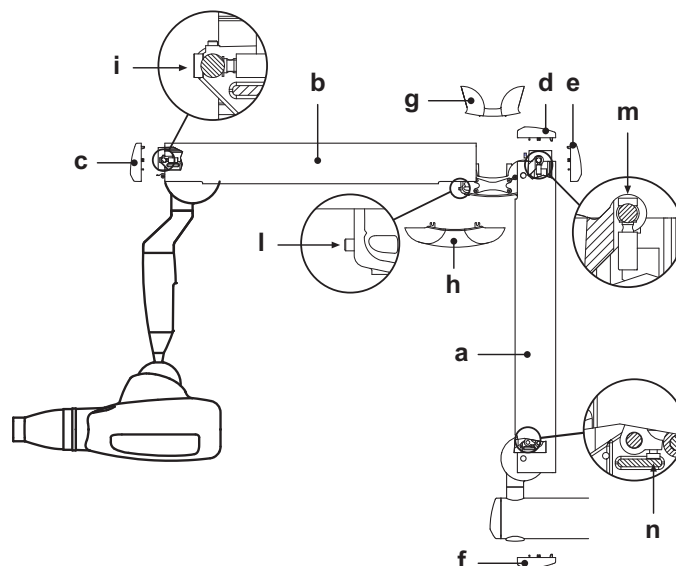

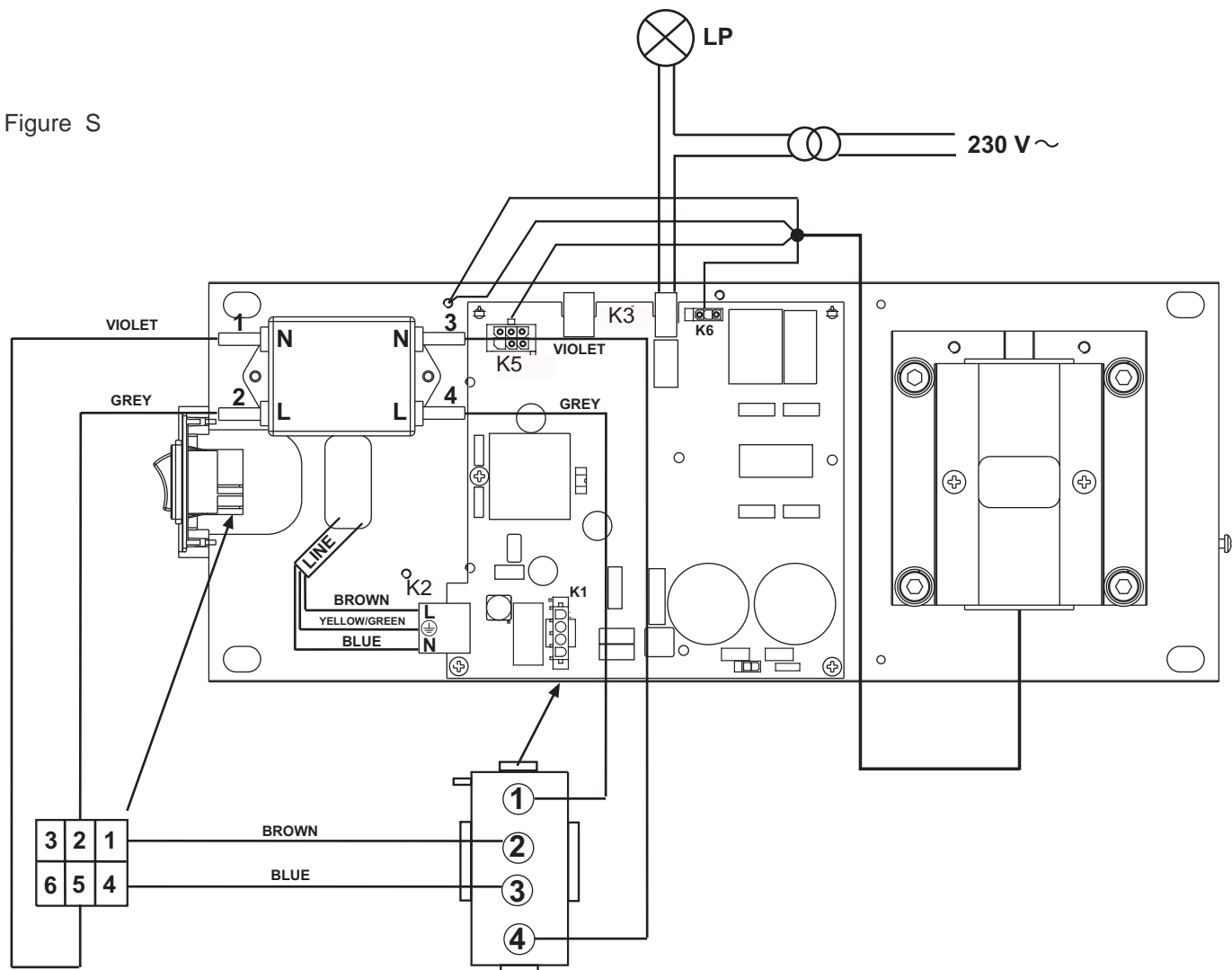

Figure R

4.10. Wall-mounted plate wiring connections

Figure S

- Connect the power cable (LINE) to terminal K2, observing the following positions:
 L - SUPPLY (**BROWN WIRE**)
 - GROUND (**YELLOW/GREEN wire**)
 N - NEUTRAL (**BLUE wire**)
- Connect the generator's power cable to the respective connectors, observing the following positions:
 K6 - **brown wire and blue wire.**
 K5 - **white wire – black wire – red wire – green wire – purple wire.**
 Eyelet connectors - Both found near the card (see figure).
-  **NOTE: Place the excess cable under the card.**
- Connect the 2 control wires (0.5 mm cross-section) for the “generator on” indicator light (LP) to connector K3.



4.11. Completion of wall-mounting plate and holder for hand-held.

Figure T and Figure U

- Pick up the cover (a) and place it over the wall-mounting plate fully tightening the grub screws (b) provided and pre-screwed on the plate.
- Place the cover (c) in the area shown in the figure. The door (d) will automatically close when the controller is closed.
- Put the controller label in the required area (e) on the cover directed according to the position in which the wall-mounting plate is installed.

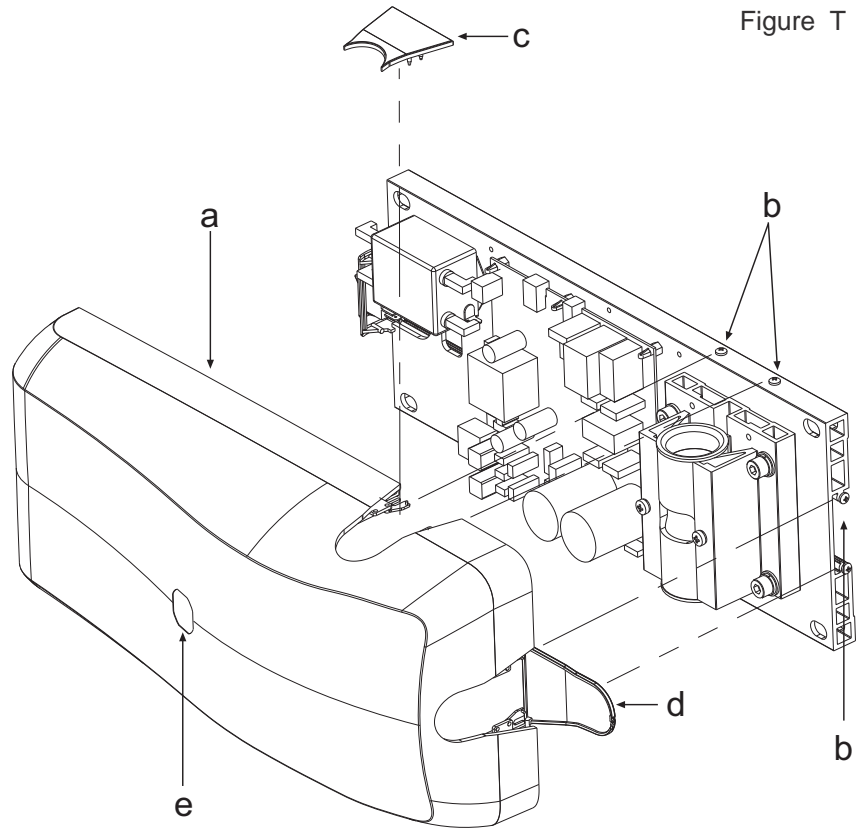

- To install the handheld's mount (f), refer to the INSTALLATION TEMPLATES.

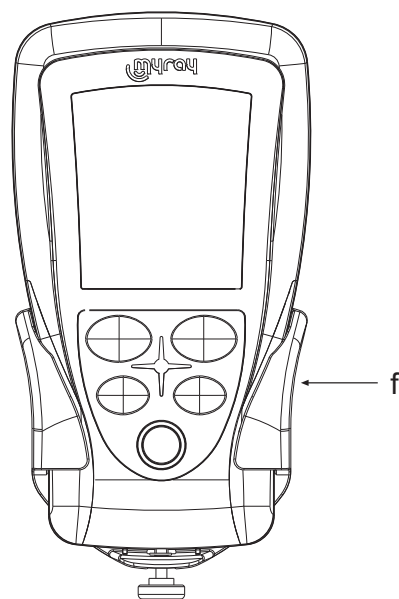

5. Factory settings

The x-ray unit is supplied with the following factory settings:

- Anode current: 6/7 mA (NORM mode).
- Sensitivity: level 19.
- Handheld stand by: 5 minutes
- Patient's built: adult (ADULT symbol selected).
- Collimator presence signaled on the display (collimator symbol off if the rectangular collimator is turned on in the head).
- Exposure times according to standard R20: 0,010-0,011-0,012-0,014-0,016-0,018-0,020-0,022-0,025-0,028-0,032-0,036-0,040-0,045-0,050-0,056-0,063-0,071-0,080-0,090-0,100-0,110-0,125-0,140-0,160-0,180-0,200-0,220-0,250-0,280-0,320-0,360-0,400-0,500-0,560-0,630-0,710-0,800-0,900-1,000.



NOTE:

These times comply with current standards I.E.C. 60601-2-7 (1999) and the ISO 497 series R'20 recommendations and **CANNOT BE MODIFIED**.

6. Turning on

6.1. Turning The X-ray equipment on and off

6.1.1. Turning on the basic X-ray unit

The control unit is turned on and off with the main switch (A), as illustrated in the figure below. The switch lights up when the control unit is energized.



NOTE: Whenever turned on, the equipment performs an operational test that takes a few seconds. Once the test has been completed, a buzzer rings and the indicator light (B) on the X-ray generator lights up at the same time.



NOTE: The exposure time and the parameters displayed when the unit is turned on are the last ones set before the central control unit was turned off. If the central control unit is left untouched for a few minutes it will go into stand-by mode. Simply press any key on the control panel to reactivate it.

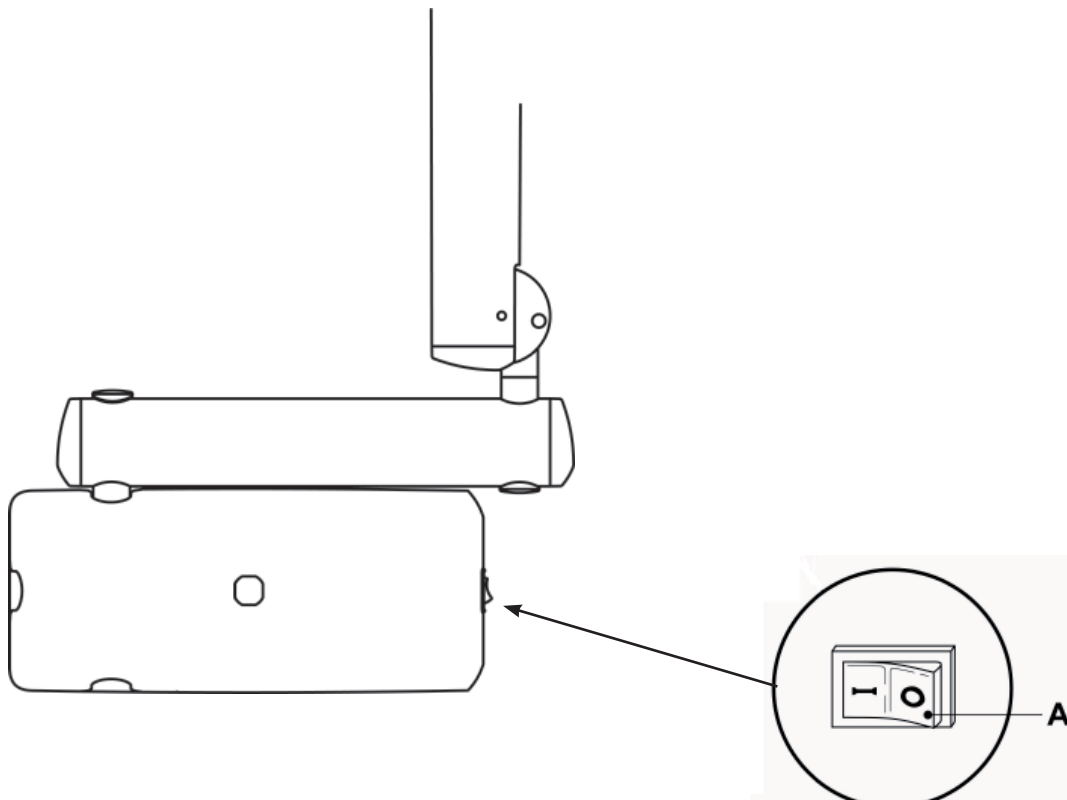

6.1.2. Turning on the handheld

The handheld is turned on by pressing any key, except for the one for x-ray emission. A buzzer rings to confirm the apparatus has been turned on. The unit will be in the standard configuration described in detail in paragraph 5 and then search for the base it works with.

If the base is off, the handheld will not indicate the field nor status "ready". If the base is latter turned on, the handheld will detect it within thirty seconds or by pressing any function key on the pushbutton panel.

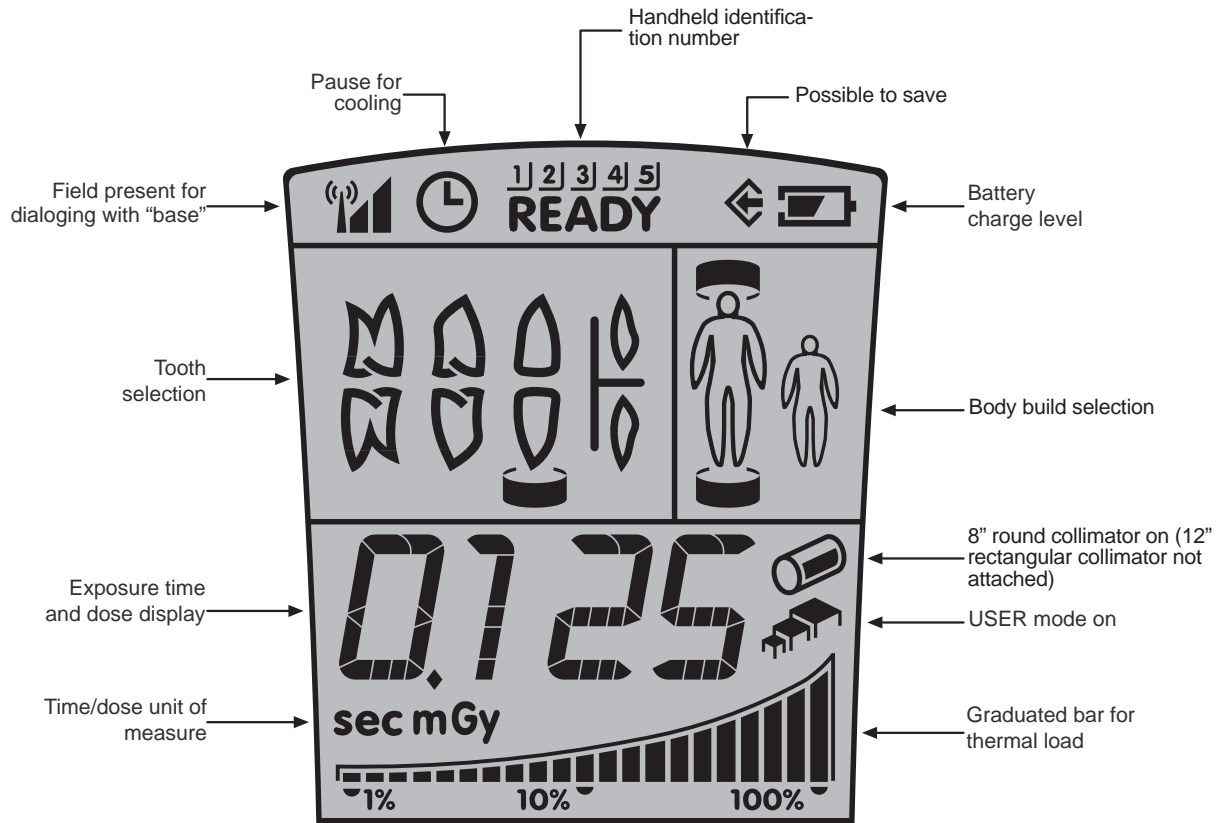





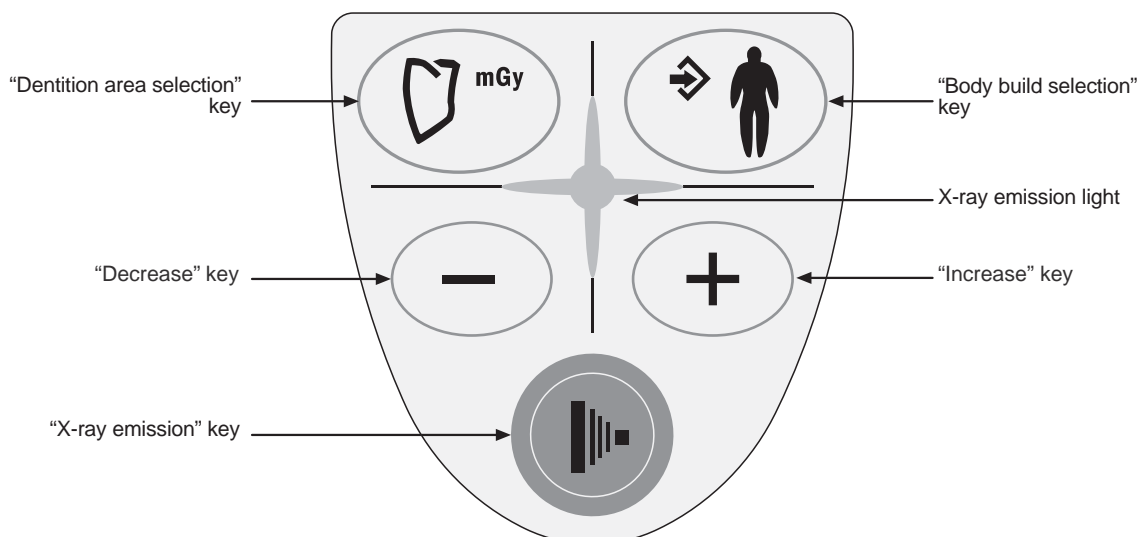

NOTE: To maximize the scope of the handheld during its use, you should keep it away from walls and metal tools and above all do not cover the internal aerial at the top of the display in addition also too rapid movement of the handheld during exposure may reduce the performance. If flow could appear on the display error is 31.

6.1.3. Control panel

As illustrated in the figure below, the handheld has four function keys and the exposure key.



The main functions of the keys on the handheld vary according to how they are pressed:

KEY	BRIEFLY PRESSED (less than 3 sec.)	PRESSED LONGER (more than 3 sec.)
	Changes over from ADULT to CHILD and vice versa (takes place when key is released).	Saves, if permitted, the sensitivity of the new tme selected. The memo icon () lights up when the data item can be saved.
	Changes amongst the various types of teeth to select the area to be examined.	Displays the exposition time of the tooth in mGy and, if the key is held down a few more seconds, in mGy*cm ² .
	Increases the exposure times in steps, according to the set scale.	Increases the scroll speed of the values in increasing order.
	Increases the exposure times in steps, according to the set scale.	Increases the scroll speed of the values in decreasing order.
	NO EFFECTS ARE OBTAINED IF THE KEY IS PRESSED LESS THAN A SECOND.	STARTS X-RAY EXPOSURE (the button has to be held down while the x-rays are being emitted, "dead man" function).

 **NOTE: "Dead man" function:** the system that starts x-ray exposure with the dedicated key on the wireless handheld allows x-rays to be emitted only when the user presses and holds down the exposure key. X-ray emission will stop if the key is released ahead of time.

 **NOTE:** The function related to pressing the key briefly is performed by pressing the key which will activate the function assigned to it. On the other hand, to perform the function carried out when the key is held down longer, press the key until the relative function is started. The buzzer will ring shortly to signal the function has started.

 **NOTE: Warm-up:** When the equipment has not been used for a prolonged period (more than 3 months) or when turned on for the first time, a number of emissions with short times (0.01-0.02 sec.) are recommended and then some pictures with 0.1 sec. intervals to better stabilize operation of the x-ray tube before using it.

6.1.4. Automatic handheld shut off

About one minute after the base is turned off the handheld automatically shuts off. Similarly, the handheld will automatically shut off if it is far away or in any case outside the operating range for interfacing with the base.

6.1.5. Hand-held stand-by time

The entire x-ray unit will switch over to stand-by (even if the base is on) and the handheld will automatically shut off after approximately five minutes of non-use to save battery power. Press any key, except for the "exposure" key, to turn the handheld back on showing the last selection made by the user. To change the stand by time, refer to chapter 14 regarding the handheld's "Technician and user setup menu".

6.1.6. Checking the set parameters

⚠ WARNING! Before actually taking an exposure, make sure the exposure parameters for the examination in progress are correctly set.

- Checking the collimator used.

The icon  on the handheld's screen should be on or off, depending on the operating mode selected:

- Icon ON: indicates that the cylindrical collimator (8") is activated.
- Icon OFF: indicates the rectangular collimator (12") is activated.

🔑 NOTE: After turning the collimator on or off, the preset exposure times and icon will automatically be modified within a few seconds.

- Checking the selected body build.

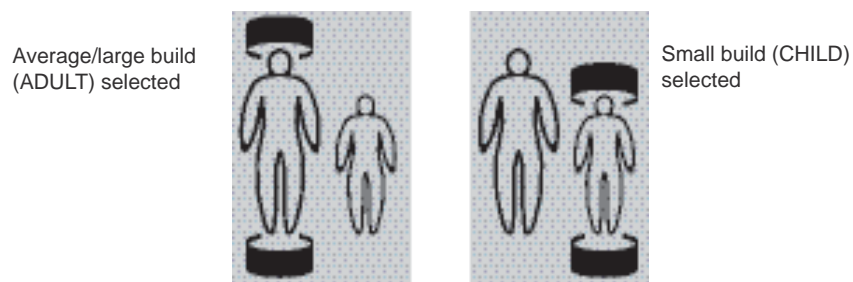

- "Child" selected: indicates the x-ray unit is set for patients with small builds.
- "Adult" selected: Indicates the x-ray unit is set for patients with average-large builds.



To change the selection, press the relative button.

🔑 NOTE: After the change has been made, the preset exposure times will automatically be modified.

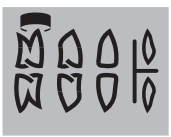
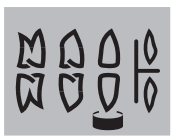
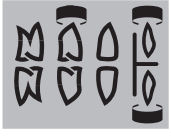
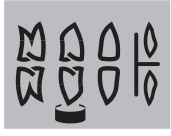
- Checking the set intraoral examination

	Upper molars		Lower incisors
	Upper canines/bicuspid or rear "bitewing"		Lower canines/bicuspid
	Upper incisors or front "bitewing"		Lower molars

6.1.7. Factory settings

The MyRay RX DC x-ray unit is supplied with the following factory settings:

- Operating mode: AUTO.
- Sensitivity: level 19.
- Handheld stand by: 5 minutes
- Exposure times as per standard R20: 0,010 - 0,011 - 0,012 - 0,014 - 0,016 - 0,018 - 0,020 - 0,022 - 0,025 - 0,028 - 0,032 - 0,036 - 0,040 - 0,045 - 0,050 - 0,056 - 0,063 - 0,071 - 0,080 - 0,090 - 0,100 - 0,110 - 0,125 - 0,140 - 0,160 - 0,180 - 0,200 - 0,220 - 0,250 - 0,280 - 0,320 - 0,360 - 0,400 - 0,500 - 0,560 - 0,630 - 0,710 - 0,800 - 0,900 - 1,000.

 **NOTE: These times comply with current standards I.E.C. 60601-2-7 (1999) and the ISO 497 series R'20 recommendations and CANNOT BE MODIFIED.**

7. Batteries and charge level indication

The handheld runs on two widely available AA alkaline batteries to assure sufficient stand-alone operation. The charge level of the batteries is given on the screen as follows:

 Battery fully charged (a symbol does not appear in the area that shows the battery charge level).

 Battery half-charged.

 Battery charge level low or almost dead (causing the handheld to automatically shut off).

 **NOTE: The batteries should be removed from the handheld if it is not going to be used for an extended period.**

8. X-ray generator indicator light

In RX DC Plus versions, the x-ray generator comes with an indicator light (B) that signals apparatus status:

- myray color (purple) > x-ray unit on (regular condition)
- Flashing myray color (purple) > stand-by (low consumption)
- Blue > x-ray one – head released
- Yellow > x-rays being emitted
- Red > fault

In the RX DC eXTend version, the indicator light is not available.

9. Position of the patient

A positioner or alignment device specific for the selected image receiver should always be used to assure the x-rays are correctly aligned regardless of the position the patient's head is in.

10. Putting the x-ray unit cone into the required position

Position the x-ray head so that the cone is aligned with the image receiver.

RX DC Plus versions feature Hypersphere technology that allows the x-ray head to turn endlessly on both the horizontal and vertical planes.

The x-ray head is initially blocked by an electromechanical brake.

The head can be tilted into the position required to take the x-ray by touching the unlock areas.

To lock it again, release the unlock areas.

Unlock button

Unlock button

 **NOTE: Firmly hold the head with both hands when putting it in place.**

It is possible to set a safety unlocking mode that allows the head to be turned only by pressing both unlock buttons. This prevents the head from unlocking unexpectedly after one of the two unlock buttons has been accidentally pressed. To activate this mode, refer to “Advanced options” in chapter 14.1.

11. Position of the X-ray plate or sensor

The parallel technique, where applicable, provides more accurate images in terms of size compared to the bisecting technique. A rectangular collimator, with 30 cm focus-skin distance, is always preferable to obtain better quality pictures. To avoid exposing the image receiver only partly (whether it is a sensor or photostimulable phosphorus plate system) an alignment device that gives rectangular collimators guidelines should be used. These lines are usually given on the alignment ring.

Parallel technique

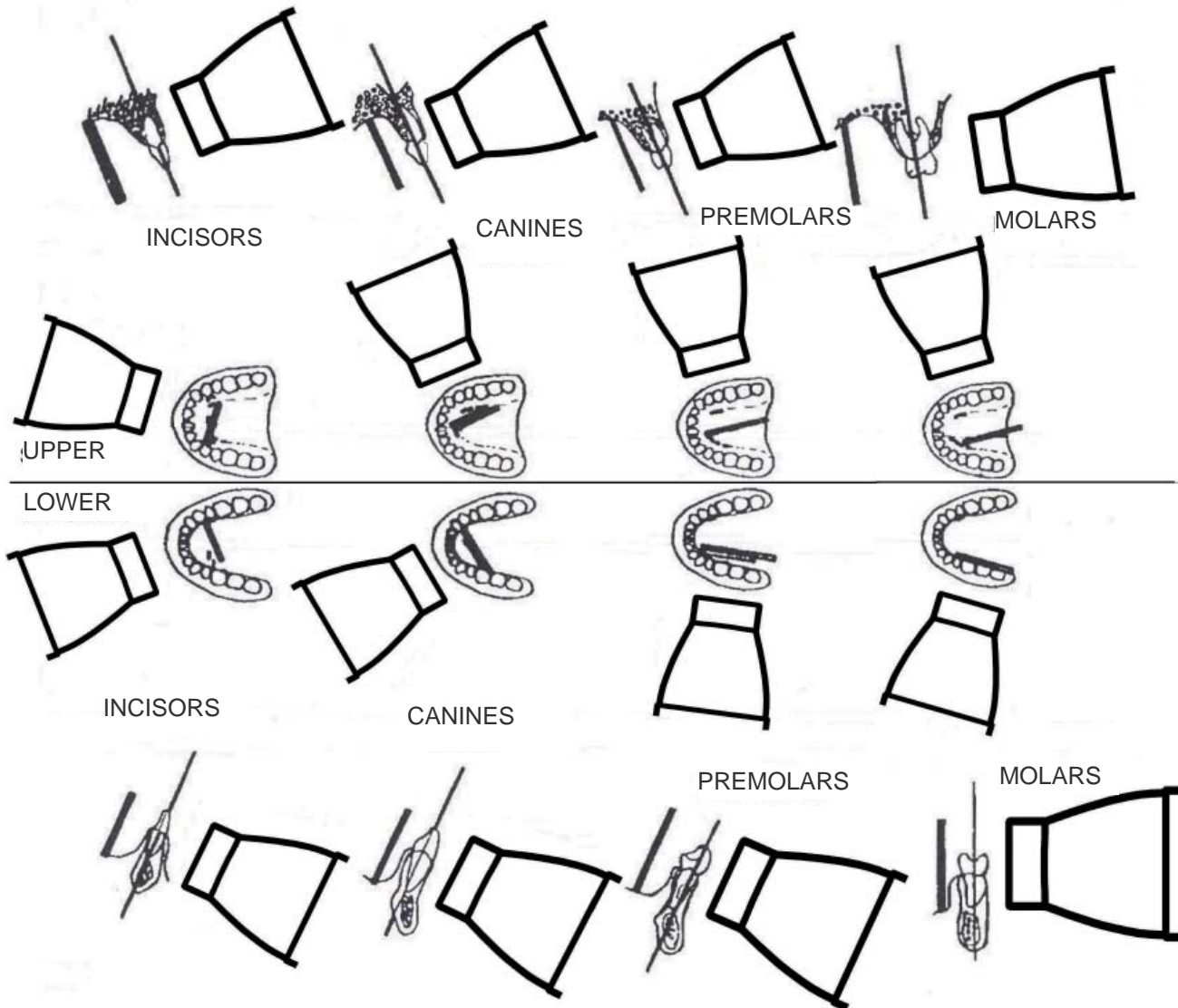

- The x ray emission axis is perpendicular to the image receiver (for example a sensor or photostimulated phosphor plate) which in turn is parallel with the tooth's long axis.
- As a result, the picture of the tooth will only be deformed by the divergence of the x rays in relation to the focus spot.
- Radiographic enlargement may reach up to 15%.
- For some "special" pictures, for example occluded ones, it may be necessary to remove the rectangular collimator and use the round one if a positioner is not present.

12. Checking the exposure time on the display

Before starting exposure, check the time setting on the handheld's screen (see the tables with the original exposure times, paragraph 3.1.4). To change the value, use keys "+" and "-".

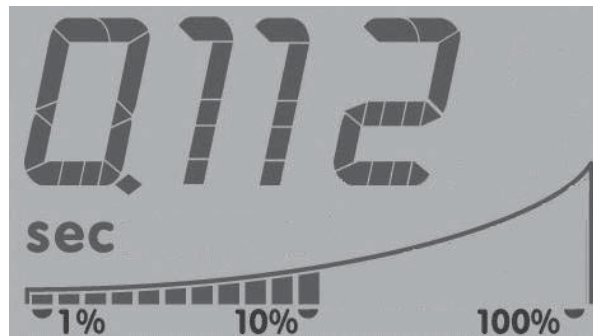

NOTE:

Changing the exposure time is only temporary: if the new time is not stored in the memory it will be lost.

12.1. Setting the exposure mode and time

The exposure parameters are set by following the directions given below:

- 1) select the tooth to be examined
- 2) select the patient size



The exposure time is automatically shown on the handheld screen.

 **NOTE:** each tooth and patient size selected is displayed for approximately 1 second according to the operating mode (En60, En63 or En65) used.





The suggested exposure time can be changed with keys  and . Exposure times ranging from 0.01s and 1.00s belonging to the R'20 scale can be set. Random exposure times different from the ones provided in the R'20 scale cannot be set.

When the exposure time displayed differs from the default setting, icon  comes on.

To save the new setting, make sure icon  is on and then press and hold down key  for approximately 2 seconds. The handheld will beep to confirm the setting has been saved. At this point, make sure icon  is off.



 **NOTE:** if the exposure time is not saved, the change made will be lost after a new entry or as soon as the handheld changes over to stand-by.

 **Important:** after customized settings have been made, the "Original exposure values charts" are no longer valid.





If icon  is displayed while the exposure time is changed, it means the set time cannot be saved for the selected tooth-patient size combination. In any case, the x-rays can be taken with the set time.

 **Important:** when the suggested exposure time is changed, the sensitivity factor is also modified (by default set to F=19). Once this change has been saved, it is applied to all the teeth and both patient sizes

The exposure time can also be modified by changing the sensitivity factor.

Press keys  and  at the same time, the actual sensitivity factor will be displayed.



Use keys  and  to change the value from 3 to 25. If the displayed value differs from the one previously saved, icon  comes on. To quit this mode, press key  or . The change made to the sensitivity factor is applied to all the teeth and both patient sizes.

The selected operating mode is always used for each tooth and patient size combination in modes En60, En63 and En65.



In AUTO mode, each tooth and patient size combination is associated to the best mode from amongst the ones available. In this mode it is not possible to assign a mode other than the default one to each combination. To set the mode, refer to paragraph 12.2 "Setting the mode and exposure time in USER mode".

To change the mode amongst En60, En63, En65 and AUTO refer to paragraph 14.2 "Setting the operating mode".

12.2. Setting the mode and exposure time in USER mode

In USER mode, it is possible to assign an exposure time and a mode from amongst En60, En63 and En65 to each tooth-patient size combination.

The default setting corresponds to the AUTOMode settings with sensitivity factor F=19

To activate USER mode regardless of the mode currently being used, press keys  and  at the same time. Icon  will come on to signal USER mode is active.

To deactivate USER mode press keys  and  again (icon  goes off).





The exposure parameters are set as directed below:

- 1) select the tooth under examination
- 2) select the patient size.









The exposure time is automatically displayed on the handheld.

 **NOTE: It is not possible to access the sensitivity factor menu in USER mode. In addition, keys  and  are inoperative in User mode.**

The exposure times and mode assigned to the tooth – patient size combinations are custom set by following the directions given below:

- 1) press and hold down key  about two seconds. Customized settings can be entered and icon  comes on.
- 2) select the desired tooth-patient size combination
- 3) change the exposure time with keys  and .

 **NOTE: it is possible to set exposure times ranging from 0.01s and 1.00s that are part of the R'20 scale.**

- 4) press keys  and  simultaneously to open the menu used to select the operating mode
- 5) select the operating mode with keys  and 
- 6) quit the menu and press key  to make the entry operative (if key  is pressed, the menu will be quit without changing the previous setting).
- 7) press and hold down key  for approximately two seconds to confirm the entry and disable customized settings (icon  goes out).

 **NOTE: it is possible to set the exposure parameters for several combinations. To do this, repeat steps 2 to 6 before going on to step 7.**

13 Procedure to be followed when taking the x-ray

- Pick up the handheld and go a safe distance away (at least 2 meters) maintaining visual contact with the patient and x-ray unit during the exposure. Make sure “READY” is indicated.

READY

- Tell the patient to stay still.
- Press and hold down the “Exposure” key on the handheld until the audible warning sound (beep) stops and the yellow light goes out.



“X-ray emission” key



Light on control panel illuminated during x-ray emission

 **NOTE: If the “EMIT X-RAY” key is released at any time, exposure will be interrupted and error code E01 will appear on the display.**



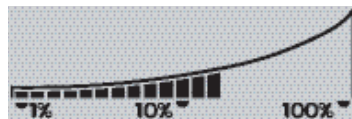

- Once exposure has been completed, it is possible to proceed with the next exposure unless the x-ray unit has reached the maximum allowable temperature. The percentage the cone exceeds the maximum allowable temperature is always shown on the screen (see icon below).









- Once the temperature has been reached, wait the pause time for cooling signaled by symbol .
- At this point the exposure function will be disabled until the screen shows “READY” again.
- As soon as “READY” appears on the handheld, another exposure can be taken.

14. Technician and user setup menu

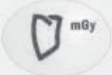
The handheld allows a number of work parameters to be viewed and edited by simply pressing a combination of keys present on the control panel.

Key  serves to confirm/save the function, key  is used to undo/quit the menu while keys  and  edit the values of the selected parameters on all the setup menus.

Proceed as directed below to access the menus:



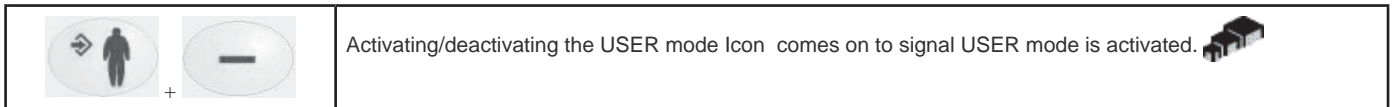

Combination of keys	Description
 + 	<p>Sensitivity levels Press these two keys to adjust the sensitivity levels (determined based on the table given below and type of sensor/receptor used). Set the current sensitivity level to a value within the allowable range (on a scale from 1 to 25), with keys “+” and “-”; to confirm the desired level and go back to the main screen press key “adult”.</p>
 + 	<p>Setting the rated current (7mA or 3.5mA) Press these two keys at the same time to set the rated current used to take the x-rays. Two values can be set: 7mA indicated by “NORM” and 3.5mA indicated by “SENS”. We highly recommend always using “NORM” unless otherwise indicated by technical service personnel. The present configuration of the x-ray unit will be displayed when the hand held is turned on.</p>
 + 	<p>Hold down these two keys to go to the set up menu (from P 01 to P 07). Press key “Build” to make the selection. Once within the individual configurations, they can be scrolled with keys “+” and “-” and selected by pressing key “Build” again. Key “tooth” quits set up without saving the setting. The configurations are given in detail below: P 01: Sets the stand by time (from a minimum of 5 to a maximum of 30 minutes). P 02: Assigns an identification tag to the x-ray unit’s base (from 1 to 5 or none). P 03: Shows the list of software versions- P 04: Handheld code display P 05: Activates/deactivates the safety unlock mode (see section 14.1) (only RX DC Plus). P 05: Reserved. (only RX DC eXTend) P 06: Selects the operating mode (En60, En63, En65 and AUTO). P 07: Sets the type of removable cone used</p>
 + 	<p>Technician setup menu Hold down these two keys when in position P07 on the user menu, to go to the advanced setup menu (from P 10 to P 18). As for the previous menu, the selection is made by pressing key “adult”. Once the single configurations have been accessed, scroll them with keys “+” and “-” and make the selection by pressing key “adult” again. The items that can be set are given below: P 10: Supply voltage setting a: A shot can be taken to improve the reading b: The mains voltage is shown in real time on the screen and refreshed every 5 seconds. If a shot is taken the reading is refreshed every second during the cool down period. c: As soon as key + or – is pressed the display is blocked until the change is confirmed. P 11: Displays the voltage or charge level of the batteries; the reading may range from 1.5 to 3Vdc. P 12: StepUp value, this value should be 3.3 + o – 0.2Vdc if a value outside this range is displayed there is a fault in the handheld card. P 13: shows the type of batteries used for the handheld: a: “ALCA” default setting, indicates that disposable alkaline batteries are being used. b: “NIHM” indicates rechargeable batteries are being used ** P 14: indicates DEMO status of the handheld a: “PALM” default setting, standard operating mode b: “DEMO” when the handheld is in this mode it does not communicate with the head but READY is shown on the display even if the control unit is shut off. P 15: indicates DEMO status of the entire system a: “SHOT” default setting, standard operating mode b: “DEMO” a pad lock shaped icon appears on the display; all the functions are operative as if in standard mode, the handheld communicates regularly with the head but x rays are not emitted when the shoot button is pressed. P 16: STAND BY function of the head is shut off P 17: When this menu is opened, the handheld starts a special procedure to deactivate the DSP default settings. A number of shots are required at a set time of 0.01 sec to recalibrate the card. Once the menu has been opened, 20 will appear on the display. Press key “Patient” again to completely cancel the previous setting. (See par. 14.5.) P 18: This menu starts the procedure so that the handheld can work with the head.</p>



14.1. Setting the safety unlock mode

The MyRay RX DC x-ray unit has a safety unlock for the ball joint.

The default setting allows the ball joint to be disengaged by simply touching one of the keys present on the front of the head. To prevent accidental contact with the keys from unexpectedly disengaging the ball joint (and therefore causing undesired movement of the head), the safety unlock mode can be activated. In this mode, the ball joint is disengaged only if both keys are activated at the same time.





To set the safety unlock mode, press keys  and  to go to the set up menu. Scroll the parameters up to parameter P05 and press key . Scroll the options to select "ON" and press key . Press key  to quit the set up menu.

14.2. Setting the operating mode

The MyRay RX DC x-ray unit features the following operating modes:

- **En60:** all the x-rays are taken at 60KV and 7mA.
- **En63:** all the x-rays are taken at 63KV and 6mA.
- **En65:** all the x-rays are taken at 65KV and 6mA.
- **AUTO:** the system automatically selects the best setting from amongst En60, En63 and En65 for each tooth-patient size combination.

 **NOTE: the current setting is displayed on the handheld for approximately 1 second for each tooth-patient size selected before the relative exposure time is shown.**





To set the operating mode, press keys  and  to go to the set up menu. Scroll the parameters up to parameter P06 and then press key . Scroll the options to find the desired operating mode and then press key . Press key  to quit the set up menu.

14.3. Setting the type of movable collimator



The MyRay RX DC x-ray unit has the following removable cones:



- Rectangular 35x45 mm (only RX DC Plus)
- Round Ø55 mm
- Rectangular 31x41 mm (to be attached to the Ø55 mm round cone)
- Rectangular 22x35 mm (to be attached to the Ø55 mm round cone)

 **NOTE: in order to obtain top performance of the x-ray unit, set the cone according to the type used.**

To set the type of cone, press keys  and  to go to the set up menu. Scroll the parameters up to parameter P07 and then press key . Scroll the options to find the type of cone used and press key . Press key  to quit the set up menu.

14.4. Restoring factory settings



To restore the factory settings (see paragraph 6.1.7.) press keys  and  to go to the set up menu. Press keys

 and  simultaneously. "rESS" will briefly appear and the handheld will be rebooted.







14.5. Calibrating the X-ray head

This operation requires the execution of 20 shots, at a pre-set time of 0.01 s, during which X-ray emission occurs. It is therefore necessary to pay close attention.

Turn on your handheld and menu position P17. To access this menu press the keys  + , scroll the

menu using the button  until you see P07, press  +  to enter the menu technical and

press the key  repeatedly until P17, press 2 times the button  enter the menu and confirm the calibration. Number 20 appears on the handheld. Make the 20 shots until the counter reaches 0. Wait about

15s and press the button  to exit the menu. If the words should appear on the remote E03, wait 10 seconds and press the button  again careful not to advance the issue ever since the firing button, in case of error, you must repeat the procedure from the beginning.

16. Control unit card Code 97660515

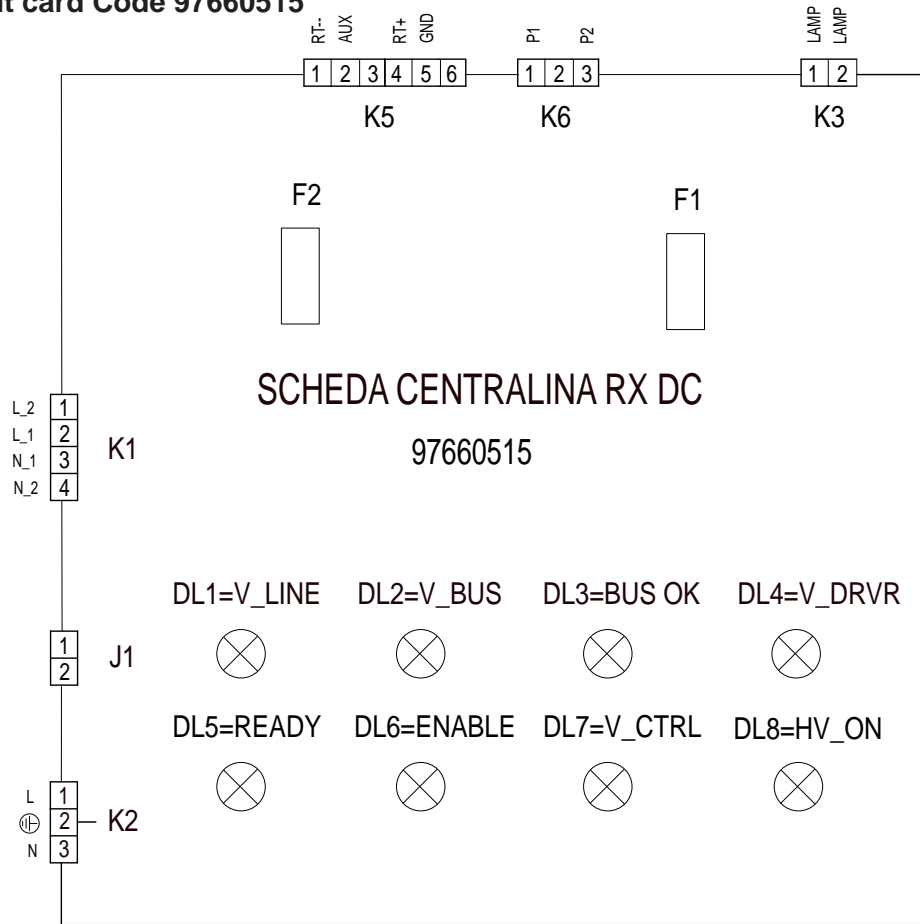

Diagnostic Led indicators

LED	Color	Status	
DL1 V_LINE	Red	On	Indicates 230Volt input voltage if 110Volt the led indicator is illuminated but not as bright.
DL2 V_BUS	Red	On	Indicates the input voltage to the capacitors.
DL3 BUS_OK	Green	On	Indicates the supply voltage is correct
DL4 V_DRVR	Green	On	Indicates the power control part fed 12Volt
DL5 READY	Yellow	On	If the head is connected it indicates READY status, relay RL1 is closed, the indicator light's signal is activated
DL6 ENABLE	Yellow	Off	It lights up if x-rays are emitted.
DL7 V_CTRL	Green	On	Indicates 15Volt output voltage to supply the card inside the head
DL8 HV_ON			Not used

Fuses

F1	6,3A	Main fuse if blown all the led indicators are off.
F2	1,6A	Fuse for capacitors if blown only DL1 is illuminated all the others are off.

Deep-switch

Con corrente di utilizzo 230Volt Tutti i deep-switch devono essere in posizione OFF, mentre se si utilizza una corrente di 110Volt il deep-switch 1 (se la versione di software della scheda è la 1.2) deve esse posizionato in ON. Se la versione del software è la 1.1 deve essere posizionato in ON solo il deep-switch 4.

17. Basic head control card Code 97660514

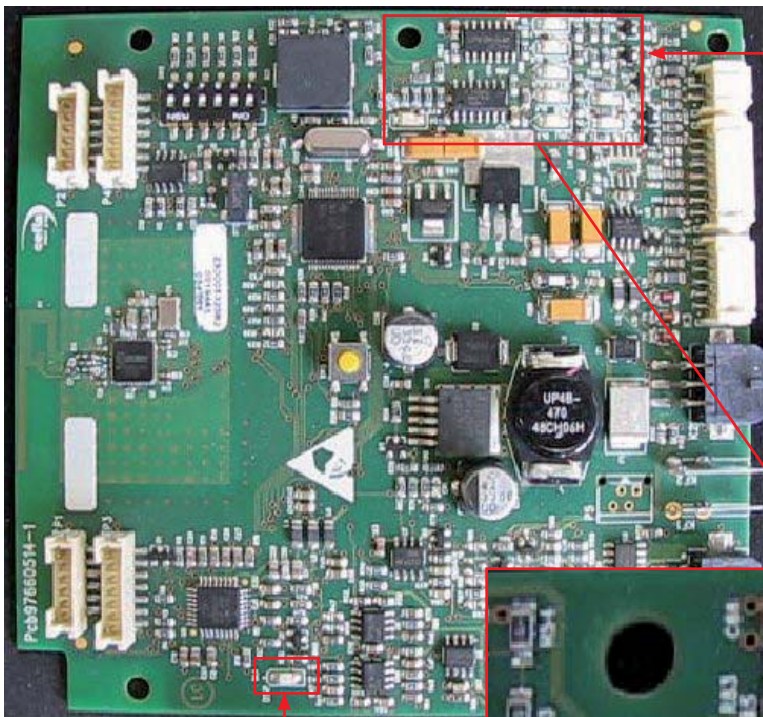
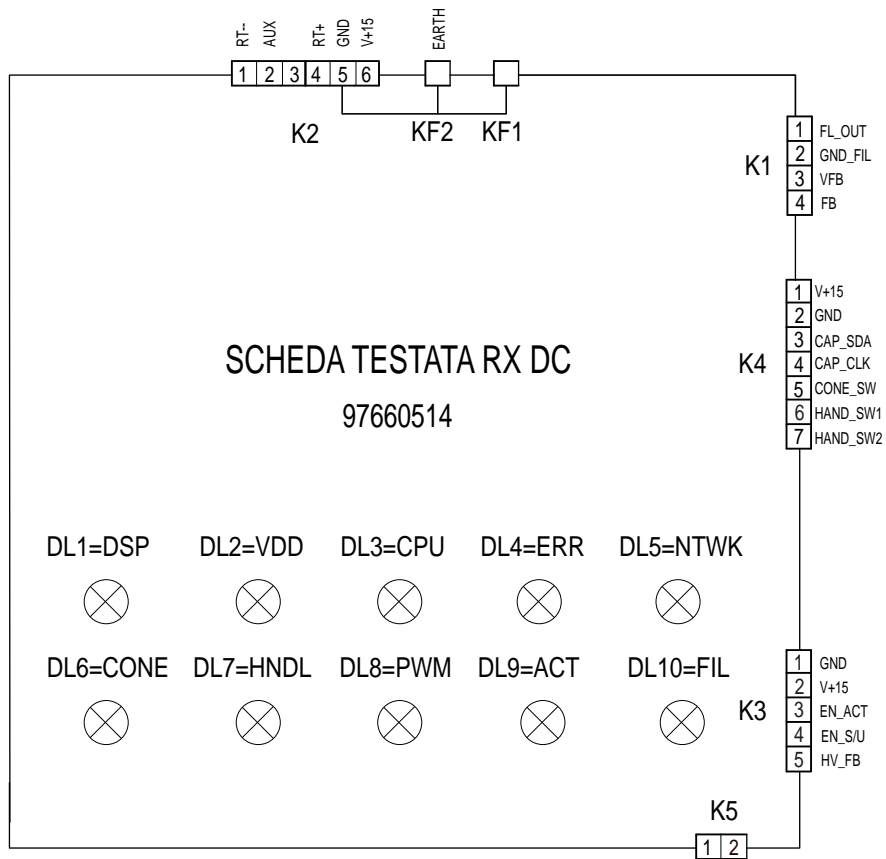

CPU led unit

Faults are signaled by two groups of leds:

- CPU led unit
- DSP led indicator

DSP led indicator

DL1=DSP



Diagnostic Led indicators

DSP LED INDICATOR

LED	Color	Status	
DL1 DSP	Yellow	Flashing	<p>If the diagnostic Led indicator flashes: once a second everything is OK once every 0.5 a second count the times it flashes and check the error in the error table very quickly check the error on the handheld</p> <p>When turned on, the DSP executes internal diagnostics and then displays the FW version using two flashing sequences separated by pauses: the first sequence indicates version code xx while the second revision code yy. The led flashes regularly immediately after showing the version. The version was not displayed in FW versions 1.2 or earlier.</p>

CPU LED UNIT

LED	Color	Status	
DL2 VDD	Green	On	Indicates 3.3Volt input voltage
DL3 CPU	Yellow	Flashing	<p>If the diagnostic Led indicator flashes:: once a second everything is OK If steady replace the card</p>
DL4 ERR	Red	Off	Lights up to signal an error
DL5 NTWK	Green	On	Indicates the radio frequency communication network has been created
DL6 CONE			Not used
DL7 HNDL	Yellow	Off	Lights up if one of the two keys is pressed
DL8 PWM	Yellow	On	Indicates the indicator light is illuminated It works simultaneously with DL5 for card 97660515
DL9 ACT	Yellow	Off	If illuminated it indicates the actuator's button has been pressed and the output signal from this card has been generated
DL10 FIL	Yellow	Off	If illuminated it indicates voltage at the filament, on during preheating

When turned on, the CPU executes internal diagnostics and then displays the FW version using two flashing sequences separated by pauses: the first sequence indicates version code xx while the second revision code yy. The led flashes regularly immediately after showing the version. Red led ERR goes out when the version is about to be displayed. If the network forming procedure is not successfully completed, led DL5 – NTWK stays off.

In the event of an **DSP error led** DSP will **flash quickly**:

- **DL1=DSP: Once every 0.5 sec.: count the number of times it flashes between pauses and read the error code in the error table.**
- **DL1=DSP: Very fast: check the error code given on the handheld.**

If the DSP is faulty, the **DSP error subcode** can be viewed on the handheld by pressing keys “tooth” and “+” at the same time, it assumes format xxxx (e.g. 8033).

The DSP can also signal an alarm condition. This condition is signaled when led DL1=DSP flashes faster than usual separated by pauses. The number of times it flashes between pauses indicates the alarm code. In the event of a CPU fault, the status of the CPU leds is as follows:

- **DL3=CPU flashing yellow**
- **DL4=ERR illuminated red**

Both conditions may be present at the same time. This indicates that two errors have been identified (from both the DSP and CPU) or the DSP caused a fault which, in turn, caused the CPU error. In this case, the error code is shown on the handheld in format Exx.

Replacing the basic head control card

Pull out the collimator and panel stop ring, take off the screw cover caps and loosen the screws that secure the lower cover. Detach all the connectors and work on the two support pins to pull out the card. Put the new card back in the correct position, being careful to run the cables behind the card support pins as shown in the figure. Make sure they do not pass in front of the x-ray collimator.

Before closing the cover, turn on the x-ray unit and make sure the diagnostic led indicator is as shown in the table. When the head's basic control card is replaced, the hand held has to be associated to the head by following the instructions given in the relative paragraph.

IMPORTANT: The head has to be calibrated with function P17 on the technical menu when this card is replaced. . Throughout this operation, 20 pictures are taken during which x-rays are emitted, therefore be extremely careful.

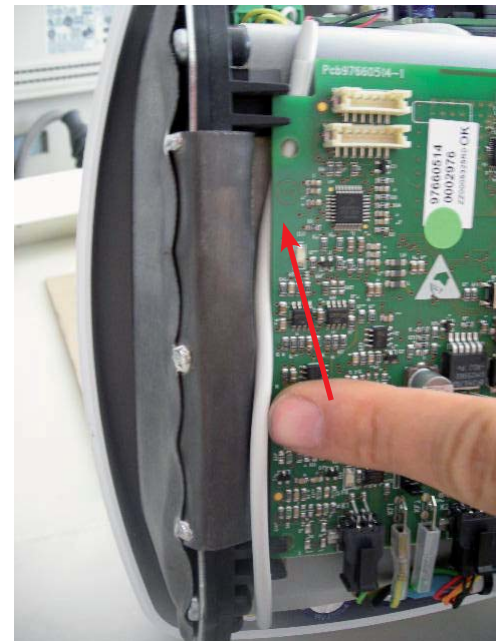
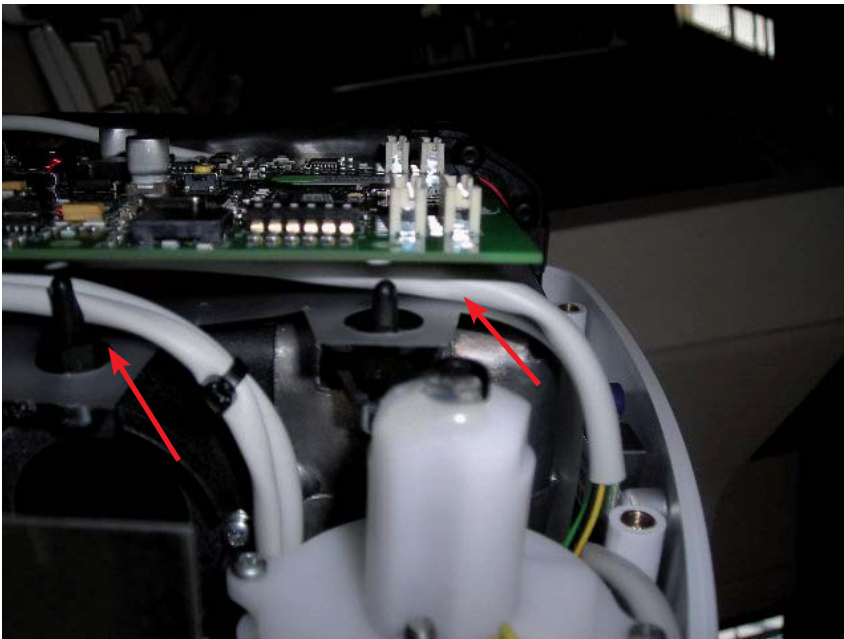

19. X-ray head

Replacement

Follow the instructions given above to remove the basic head control card Code 97660514. Detach all the cables connected to the head that may get in the way. Loosen the screw A that secures the head, move it to the rear and lift it as shown in the figure.

IMPORTANT: The head has to be calibrated with function P17 on the technical menu when replaced. . Throughout this operation, 20 pictures are taken during which x-rays are emitted, therefore be extremely careful. (See par. 14.5.)

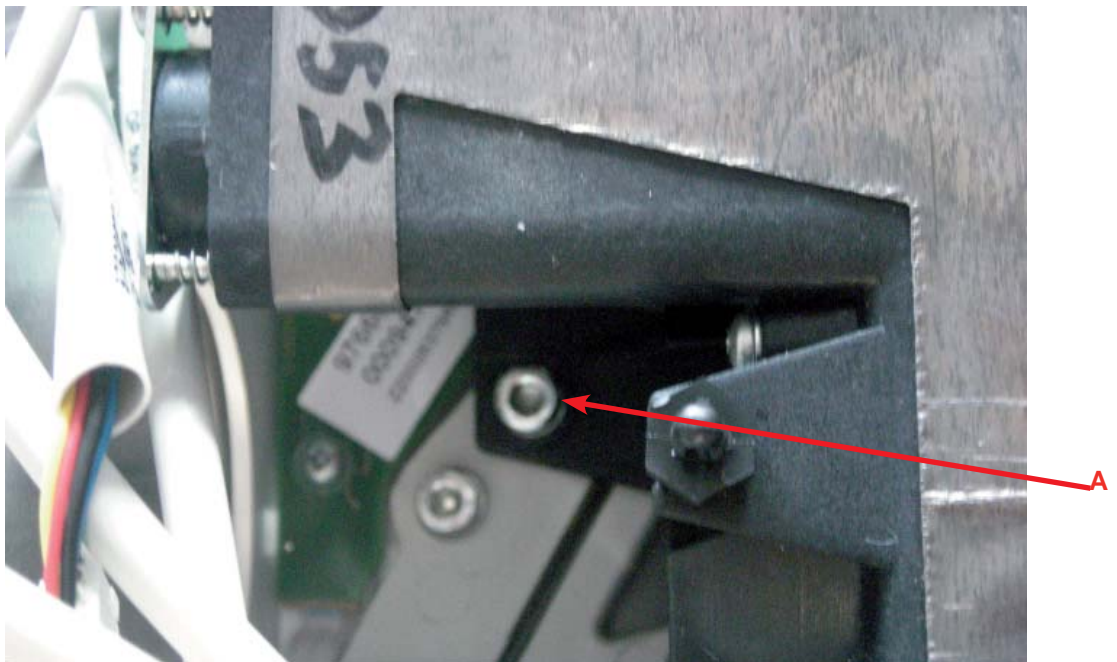

To reinstall the head, perform the procedure in reverse order, being careful to lay the cables properly.

Radiogenic palmtop computer-head association

If the control palmtop computer or the head control Code 97660514 needs to be replaced it is only necessary to associate the palmtop with the head. To do this, you first need to set the head in combination mode (an operation that can be done in two different ways) then send a recognition signal from the head's remote control.



1) Setting the head in combination mode.

This procedure can only be activated within ten seconds of the radiographic unit being turned on.

- Remove the collimator from the head, turn on the radiographic unit. You will hear a beep, wait for a few seconds until the light on the head turns violet, then turn the collimator microswitch on and off at least seven times. The head will emit a beep that confirms the head has switched to combination mode and the led on the head will go red.
- Remove the collimator from the head, turn on the radiographic unit, you will hear a beep, wait for a few seconds until the light on the head goes violet, press and release the right-hand head release button, press and release the collimator microswitch, press and release the left-hand head release button. You will hear a beep that confirms the head has switched to combination mode and the led on the head will go red.

If the procedure is unsuccessful, turn off the head, wait a few seconds and start again.

2) Send the recognition signal from the palmtop computer to the head:

Turn on the handheld and go to menu P18. This menu is accessed by pressing keys  + . Scroll

the menu with key  until P07 appears. Press  +  to access the technical menu and

press key  several times until P18 is displayed. Press key  to open the menu and confirm as-

sociation. E14 will appear on the remote control. Press key  to reset: If association has been successfully

completed the radio field icon  should appear on the control hand held with the word READY. If this is not the case, repeat the operation.

Turn on the hand held and go to menu P18. Press keys  +  to access this menu. Scroll the

menu with key  until P04 appears. Press  +  to go to the technical menu and press key

 several times until P18 is displayed. Press key  to open the menu and confirm association. If

association has been successfully completed the radio field icon  with the word READY. If this is not the case, repeat the operation.

IMPORTANT: If the X-ray unit-Handheld are associated using this mode, the x-ray unit has to be calibrated with function P17 on the technician's menu.

Exercise extreme caution during this operation as 20 pictures are taken at a preset time of 0.01s, throughout which x-rays are emitted(see par. 14.5).

19.2. Check occupation of radiofrequencies for RXDC MyRay PDA

The procedure described below enables the user to check the availability of radio frequencies on the channels of communication used by the RXDC MyRay remote control PDA.

Open the battery compartment of the PDA and remove the batteries.



fig.1

Using a fine-tipped screwdriver, move selector 2 of the dip-switch shown in figure 2 in the direction indicated by the arrow.



fig.2

The PDA enters radiofrequency disturbance detection mode. When switched on, the display shows the channel to be examined (C11). Pressing "+" and "-" chooses the channel (C11-C26). Pressing the "patient" key displays a percentage value representing the signal quality on the selected channel. See fig. 3

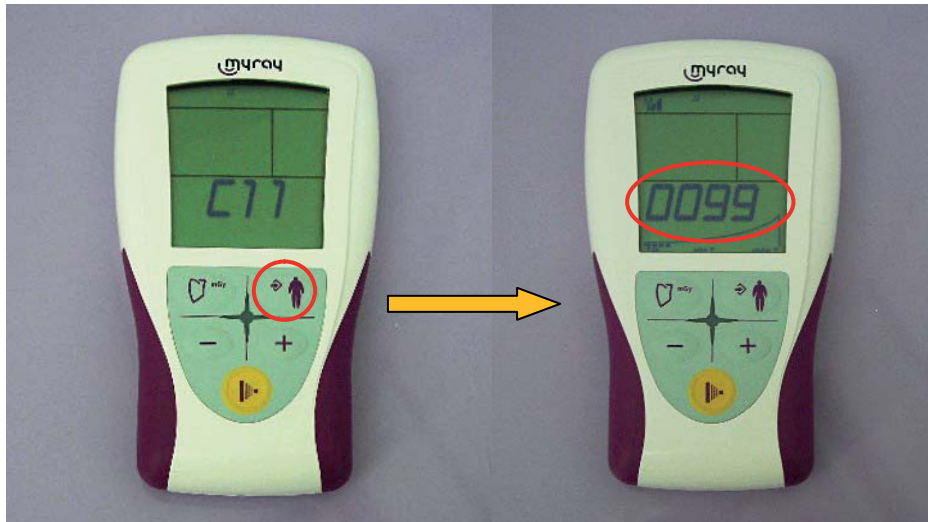



fig.3

If, on most channels, the values are higher than 80%, PDA features are guaranteed. During normal use, the PDA performs automatic scans of the channels available and uses the frequencies available for communication.

Once the test on the radiofrequencies has been completed, remove the batteries again, moving selector 2 of the dip-switch shown in fig. 2 back to the starting position.

Error codes given on the handheld



When an error appears on the handheld screen it can be reset by pressing keys  or  to set the x-ray unit back to READY. If the error is still displayed even after pressing the two keys mentioned above, refer to the error code and solution given in the table below.

Handheld errors		
N°	Error code description	Solution
E 01	Button released in advance	Hold down the button to take the x-ray again until the beep stops.
E 02	Max. shooting time 7s	Take the x-ray again. If the problem persists, go near the head and try again.
E 03	CPU internal error	Take out the batteries to reset the handheld. Wait a few seconds, put the batteries back in and take the x-ray. If the problem persists, replace the handheld.
E 04	Software internal error	Take out the batteries to reset the handheld. Wait a few seconds, put the batteries back in and take the x-ray. If the problem persists, replace the handheld.
E 05	ALU internal error	Take out the batteries to reset the handheld. Wait a few seconds, put the batteries back in and take the x-ray. If the problem persists, replace the handheld.
E 06	Status switching too long	Take the x-ray again. If the problem persists, go near the head and try again.
E 07	RF field too low (16 consecutive messages lost)	Take the x-ray again. If the problem persists, go near the head and try again.
E 08	Incorrect firmware version	Update the firmware for the handheld and head control card.
E 09	Wrong handheld serial number	Enter the correct handheld serial number.
Head control card errors Code 97660514		
N°	Error code description	Solution
E 10	Button released in advance	Hold down the button to take the x-ray again until the beep stops.
E 11	Cone type error	Wait approximately 4/5 before taking another x-ray after removing or putting on the collimator cone.. Hold down the button to take the x-ray again until the beep stops.
E 12	Hardware internal error	Reset the x-ray unit by shutting it off with the main switch. Wait a few seconds, turn the x-ray unit back on and take the x-ray again. If the problem persists, replace the basic head control card Code 97660514
E 13	Emission time greater than 4.9s	Reset the x-ray unit by shutting it off with the main switch. Wait a few seconds, turn the x-ray unit back on and take the x-ray again. If the problem persists, replace the basic head control card Cod. 97660514
E 14	Internal cycle error	Reset the x-ray unit by shutting it off with the main switch. Wait a few seconds, turn the x-ray unit back on and take the x-ray again. If the problem persists, replace the basic head control card Code 97660514

E 15 E 16	DSP error	DSP error detected. Check the error subcode by press keys “tooth” and “+” at the same time.	
		0001	Overvoltage HW.
		0002	Overcurrent HW.
		0004	Overvoltage SW. It may be caused by incorrect calibration or after an extended period of inactivity, Perform the calibration procedure from menu P17. (par.14.5.)
		0008	Overcurrent SW. It may be caused by incorrect calibration or after an extended period of inactivity, Perform the calibration procedure from menu P17. (par.14.5)
		0040	Anode voltage not zero. Replace the basic head control card code 97660514.
		0080	Anode voltage not zero. If the problem persists, replace the basic head control card code 97660514.
		0100	Filament voltage not zero. If the problem persists, replace the basic head control card code 97660514.
		0200	Tube filament faulty or cable (code 97520672) between monoblock card (code 97660511) and head card (code 97660514) not connected or interrupted.
1000	Parameter incorrect. If the problem persists, try resetting the calibration values from menu P17 and then calibrate again. (par.14.5.)		
E 17	Actuator overload	Indicates the actuator that disengages the ball joint has been used for a prolonged period. Wait for the device to cool down (about 15 minutes) to reset the system. This error is given only in version 2.0.	
E 18	Mains voltage over maximum limit (more than 15%)	Make sure the supply voltage corresponds to the rated one (menu P10)	
E 19	Mains voltage below minimum limit (more than 15%)	Make sure the supply voltage corresponds to the rated one (menu P10)	
E99	General error	Shut off the x-ray unit with the switch to reset it. Turn the x-ray unit on after a few seconds and take a picture gain; if the problem persists, contact technical assistance.	
Control unit card errors Code 97660515			
E 30	Tracking error	Make sure led DL5 on control unit card code 977660515 is yellow and illuminated. If it is not, replace the card. Check the error subcode by press keys “tooth” and “+” at the same time.	
		0010	KV incorrectly set.
		0020	mA incorrectly set
		0030	KV and mA mA incorrectly set
		If the error occurs systematically, calibrate the x-ray unit with function P17 on the technician’s menu, cancelling the existing one; if the problem persists contact technical assistance. (par.14.5.)	
E 31	No RF trigger pulse (field ZigBee)	0400	Take the x-ray again. If the problem persists, go near the head and try again.
E 32	DSP disabled by CPU	2100	Shut off the x-ray unit with the switch to reset it. Turn the x-ray unit on after a few seconds and take a picture gain; if the problem persists, contact technical assistance.
E 33	Head power cable disconnected or pinched	8030	Make sure the power cable for the x-ray unit is connected to the control unit card code 97660515. Measuring with tester the resistance between connector thick cables of power (typically brown and white or grey and purple). In normal conditions the resistance should result lesser than 1 ohm, otherwise must be verified and check continuity of the cables between the control unit card and x-ray unit. If the problem persists, replace card code 97660515.

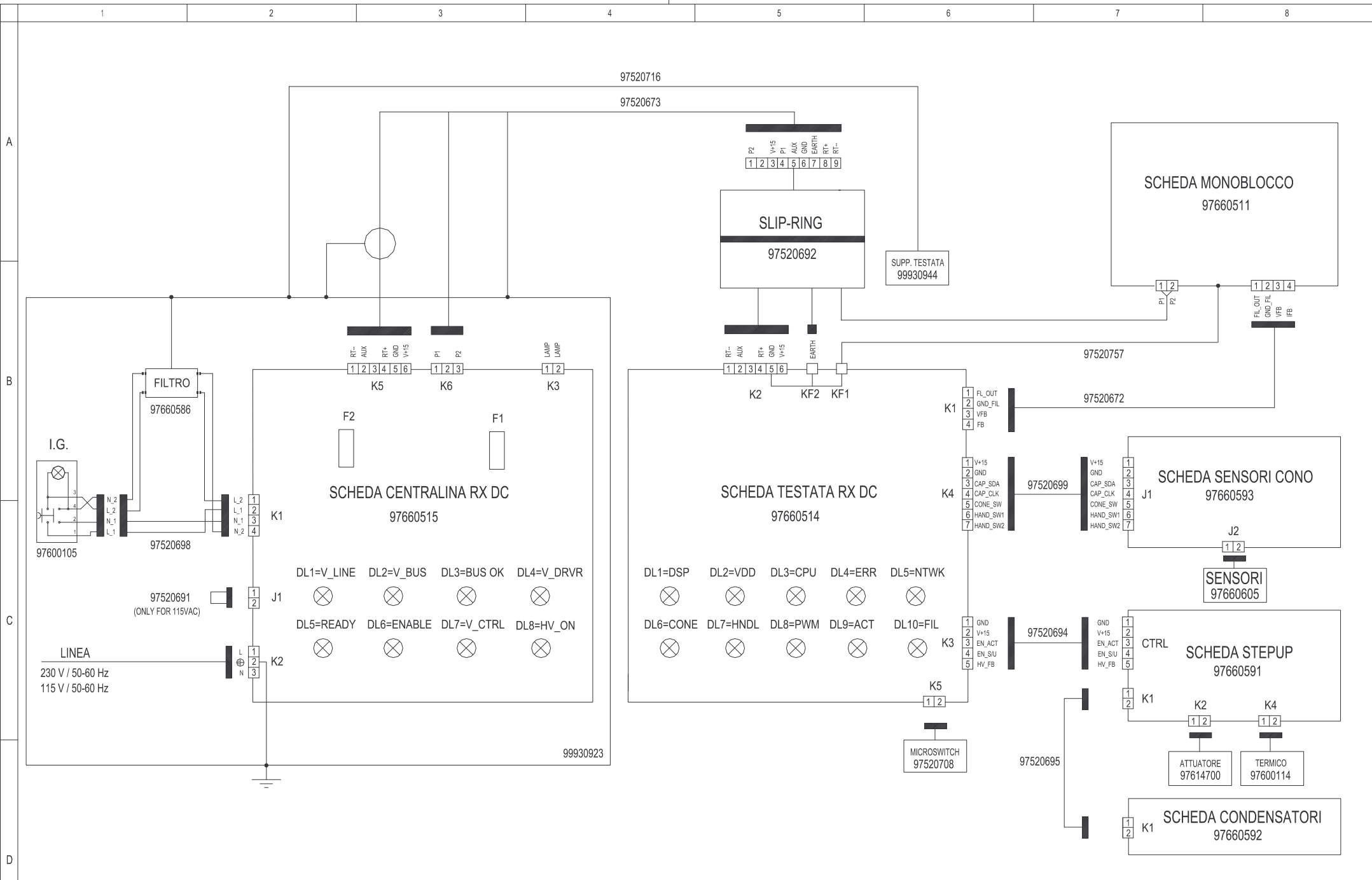

COMPLESSIVO ELETTRICO: RADIOGRAFICO DC
 ELETTRIC WIRING
 SCHEMA ELECTRIQUE
 SCHALTPLAN
 ESQUEMA ELECTRICO

FIRME E DATA
 DIS. PALOMBO
 APPR. PIOGGIA
 DATA 25/09/07

CODICE
PRT97040592
 REV. 0 FOGLIO 1 DI 1

CEFILA DENVERIALE - UFFICIO TECNICO - VIA BEOCCAZI 14/C (MOD. A/B) ITALIA